

Fan Coil Unit - EC Fan - Waterside 4 Pipe and 2 raise/lower (floating point) valves.

The IQeco standard strategy controls a fan coil unit's heat/cool outputs, and electronically commutated fan, in response to a thermistor temperature sensor with a local setpoint knob and a local switch input (window contact, pushbutton, or Passive Infra Red movement detector input). The WR4 strategy is for waterside 4 pipe units controlling 2 raise/lower (floating point) valve actuators. The strategy is designed to work with TB/TS Trend Thermistor Room Sensors. The strategy supports the fitting of a WMB Room Display module without further configuration.

The strategy is designed for use with an IQeco31 and is part of the Plus library.

Order code: IQE31/[y]/BAC/ECFANWR4P/[p] where [y] is unit type F = fixed, P = programmable and [p] is the voltage option.

The strategy will also fit IQeco35 and IQeco38 and can be field downloaded to suitable controllers using SET and the standard solutions.

Inputs

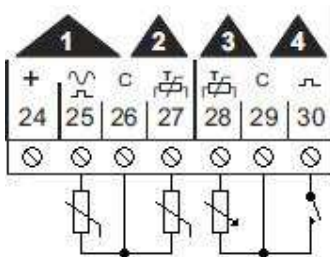

The following real sensors and digital inputs are connected to the input channels and their values can be monitored by text comms (including IC Comms):

Real Sensors

IN 1: "Local Discharge Air Temp" (S21), the thermistor temperature sensor for the discharge air.

IN 2: "Local Space Temperature" (S22), the thermistor temperature sensor for the space.

IN 3: "Local Setpoint Adjust" (S23), the local setpoint adjustment potentiometer (scaled in the range -0.5 to +0.5). This generates a setpoint trim in the range -1°C to +1°C or -1°F to +1°F when the knob 'Offset Range' (K3) value is set to 2.

Real Digital Inputs

IN 4: "Window Pushbutton PIR" (I24) this input can be either a window contact which opens, or a pushbutton, or PIR (passive infra red occupation detector) which closes when the occupation override is required. The type of input is defined by switches 'Window Mode 1=Enabled' (W41) and '0=Pushbutton 1=PIR' (W42).

FCU EC Fan WR4

Outputs

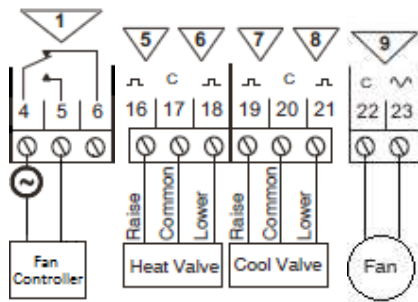

OUT 1: "Occupation Relay" (D1), this output is used to switch power to the fan controller.

OUT 5,6: "Heating Valve" (D5), these outputs are connected to a raise/lower (floating point) actuator to raise (open) and lower (close) respectively.

OUT 7,8: "Cooling Valve" (D7), these outputs are connected to a raise/lower (floating point) actuator to raise (open) and lower (close) respectively.

OUT 9: "EC Fan" (D9), this is connected to the speed input on the EC fan controller.

Default Operation

The behaviour of the strategy before any configuration of knobs as switches is as follows:

The default occupancy state of the strategy is unoccupied.

In most cases when the controller is powered on the fan outputs will not operate as the space temperature used for control will be within the deadband for the unoccupied state.

There are 3 ways to take the strategy out of the unoccupied state:

1. Set Knob "Remote Occupancy" (K11) to 0.
2. Using a pushbutton connected to IN4. Press the pushbutton once; this should place the unit into bypass. The bypass state is active until another press of the pushbutton or timeouts after 30 minutes.
3. Use the service button to put the unit into occupied. Details are in "Service Button - Occupancy" section of the strategy datasheet.

The fan output may not be operating for the following reasons:

- a. The fan anti cycling strategy is active. Once switched off the fan will not start for 5 minutes.
- b. Changes to the knobs and switches from the defaults are overriding the fan control.
- c. The occupancy state is unoccupied.

WallBus Interface Eco

This Standard Strategy can be used with WMB Units which provide Temperature, Humidity, DewPoint and CO2 values to internal Strategy Sensor Modules.

When adding WMB Units to the system, 963, IQview8 and IQview4 and other User displays will discover these Sensor Modules and display them in their lists.

WMB units which do not support Humidity or CO2 values will send a value of 0 to the 963 and user displays.

To stop the User Display from showing any one Sensor Module delete the label string in that module.

For example to prevent the User Display from showing Humidity, delete the label (\$ parameter) in sensor 32.

You can delete parameters in fixed strategies using one of these methods: parameter viewer in SET system view, live adjust in SET drawing view or by a text comms message such as S32(\$="").

You cannot change connections between modules in this fixed strategy.

The Strategy can operate with the new RS-WMB, RD-WMB and RV-WMB sensors which are detailed inTA201348. It can also operate with the older version of RD-WMB.

The new WMB sensors are available with options for:

Temperature - RD-WMB T, RS-WMB T, RV-WMB T
Temperature and Humidity RD-WMB TH, RS-WMB TH, RV-WMB TH
Temperature, Humidity and CO2 RD-WMB THC and RS-WMB THV.

The Strategy is designed to operate with RD, RS and RV of all the available types.

Sensors which do not support Humidity or CO2 will continue to scroll through all the variables with a display of 0 unless the input in the interface module is deleted.

For RD-TH, RS-TH, RV-TH sensors
Delete the PVid in t2110V to prevent the RD displaying CO2 with the value 0

For RD-T, RS-T, RV-T sensors
Delete the PVid in t2110V to prevent the RD displaying CO2 with the value 0
Delete the PVid in t216V to prevent the RD or RV displaying Humidity with the value 0
Delete the PVid in t2111V to prevent the RD or RV displaying Outside Air Temperature with the value 0

The RV sensors have configuration settings such as button graphics and CO2 thresholds. The Strategy does not allow you to link these settings to strategy. Configuration settings for RV can only be made through the display. See Trend Data sheet TA201354. For RV and RD meters you can display CO2 from a remote controller by setting up an IC comms to Sensor 34 and deleting the PVid in t2O4 so that the value in S34 is not overwritten. This standard solution does not support a CO2 sensor hard wired to the controller.

Knobs Switches <21

The following knobs and switches are grouped by the role they are intended to play within the strategy. They can be monitored and changed by text comms (including IC Comms). Some can be monitored using display and directory modules (e.g. using IQView):

Modules	Role
1-10	Adjustments - Items the users may want to change.
11-20	Remote Control - Items that are expected to receive IC Comms e.g. frost protection.
21-30	Overrides - Items that enable control to be overridden e.g. heating override.
31-40	Settings - Items that should be set up during commissioning.
41-50	Options - Items that select an option or behaviour e.g. serial parallel fan.
51-60	Energy - Items related to energy.

Adjustments

K1 'Pushbutton PIR Timeout', this knob defines the time in minutes for which the activation of the pushbutton/PIR input overrides the unit into the occupied state. The default value is 30 minutes.

K2 'Setpoint Adjust Timeout', this knob defines the time in minutes for which any setpoint trim will be applied to the setpoint. The default value is 60 minutes.

K3 'Offset Range', this knob is used to define the range of 'Local Setpoint Adjust' (S23). The 'Local Setpoint Adjust' (S23) is scaled to give a range of -0.5 to +0.5; this is multiplied by the 'Offset Range' to give the setpoint trim which is applied to the 'Remote Setpoint' (K14) to produce the 'Setpoint' (S3). The default value is 2°C or 2°F producing a value between -1°C to +1°C or -1°F to +1°F.

K4 'OCC Deadband', this knob defines the difference between the heating and cooling setpoints during occupation. The default value is 1°C or 2°F.

K5 'NOCC Deadband', this knob defines the difference between the heating and cooling setpoints during non-occupation. The default value is 25°C or 45°F.

K6 'Standby Deadband', this knob defines the difference between the heating and cooling setpoints during standby. The default value is 8°C or 15°F.

K7 'Heating Setpoint', this knob defines the heating setpoint when separate setpoints are selected using switch 'HeatCool Setpoint 1=Separate' (W36). The default value is 19.5°C or 67°F.

K8 'Cooling Setpoint', this knob defines the cooling setpoint when separate setpoints are selected using switch 'HeatCool Setpoint 1=Separate' (W36). The default value is 20.5°C or 69°F.

W1 'Unit Bypass Request 1=Active', this switch is set to ON if the unit is in bypass and can be used to put the unit into or out of bypass. The default state is OFF.

Remote Control

K11 'Remote Occupancy', this knob defines unit's occupancy state: 0(Occupied), 1(Unoccupied), 2(Bypass), 3(Standby). It can be overridden into bypass (equivalent to Occupied within the unit) from any occupation state by the pushbutton or from standby by the PIR. The state is overridden to unoccupied by the switch 'Remote Shutdown 1=Shutdown' (W11) or the window contact (IN24). The definition of the occupancy states are detailed below under Occupancy States. The default value is 1(Unoccupied).

K12 'Remote Space Temperature', this knob is used instead of input 'Local Space Temperature' (S22) when the input has an out of limits or read alarm. It can also be used by setting switch 'Temperature Select 1=Remote' (W34) to ON. The default value is 22°C or 71°F.

K13 'Remote Setpoint Offset', this knob is used instead of input 'Local Setpoint Adjust' (S23) to provide the setpoint trim. It is added to the 'Remote Setpoint' (K14) when the input (S23) has an out of limits or read alarm. It can also be used by setting switch 'SP Offset Select 1=Remote' (W35). The default value is 0°C or 0°F.

K14 'Remote Setpoint', this knob is combined with the setpoint trim to provide the 'Setpoint' (S3). The default value is 22°C or 71°F.

K15 'Remote Fan Speed', this knob is used to set the fan speed in the range of range: 0 (off), 1 (low), 2 (medium), 3 (high), or 4(auto). To ensure that the 'Remote Fan Speed' value is used when sensor 'Local Fan Speed' (S27) is fitted the switch 'Fan Speed Select 1=Remote' (W39) must set to ON. The fan will be switched off during non-occupation unless there is heating demand (fabric protection) which selects low fan speed. The default value is 4(auto).

K17 'Heating Flow Temperature', this knob sets the temperature used to calculate the energy consumption of the unit when in heating mode. The default value is 80°C or 176°F.

K18 'Cooling Flow Temperature', this knob sets the temperature used to calculate the energy consumption of the unit when in cooling mode. The default value is 6°C or 43°F.

W11 'Remote Shutdown 1=Shutdown', this switch when set to ON forces the unit into the unoccupied state, disables cooling, only allows sub-zero heating, and disables fabric protection during non-occupation. The default state is OFF.

W12 'Frost Condition 1=Frost', this switch when set to ON forces the unit into a frost condition during non-occupation. During the frost condition the heating demand is fixed at 98%. The default state is OFF.

Knobs Switches 21 - 40

Overrides

K21 'Heating Override Value', this knob sets the value used to drive the heating output when switch 'Heating Override 1=Enabled' (W21) is enabled. The default value is 0%.

K22 'Cooling Override Value', this knob sets the value used to drive the cooling output when switch 'Cooling Override 1=Enabled' (W22) is enabled. The default value is 0%.

K28 'Fan Speed Override Value EC', this knob sets the value used to drive the fan speed output when switch 'Fan Override 1=Enabled' (W27) is enabled. The analogue value 0 is OFF and 100 is full speed. The default value is 50.

W21 'Heating Override 1=Enabled', this switch when set to ON enables heating override and the heating valve output is set to the value on the knob 'Heating Override Value' (K21). The default state is OFF.

W22 'Cooling Override 1=Enabled', this switch when set to ON enables cooling override and the cooling valve output is set to the value on the knob 'Cooling Override Value' (K22). The default state is OFF.

W27 'Fan Override 1=Enabled', this switch when set to ON enables fan to be overridden and the fan outputs are set to the speed selected on the knob 'Fan Speed Override Value EC' (K28). The default value is OFF.

W28 'Water Balance 1=Enabled', this switch when set to ON forces all valve outputs to 100%. The default state is OFF.

Settings

K39 'Minimum Fan Speed Setpoint', this knob defines the minimum speed permitted by the EC fan. The default value is 37%.

K40 'Maximum Fan Speed Setpoint', this knob defines the maximum speed permitted by the EC fan. The default value is 70%.

W31 'Service Button Mode 1=Enabled', this switch when set to ON allows the service button to be used as an input into the strategy. The default state is ON.

W32 'Overrides 0=Disabled 1=Enabled', this switch when set to ON allows the strategy overrides to be used. The default state is ON.

W34 'Temperature Select 1=Remote', this switch when set to ON forces the strategy to use the value from knob 'Remote Space Temperature' (K12) and not sensor 'Local Space Temperature' (S22). The default state is OFF.

W35 'SP Offset Select 1=Remote', this switch when set to ON forces the control to use the value from knob 'Remote Setpoint Offset' (K13) and not sensor 'Local Setpoint Adjust' (S23). The default state is OFF.

W36 'HeatCool Setpoint 1=Separate', this switch when set to ON enables the control to use separate setpoints for heating and cooling use knobs 'Heating Setpoint' (K7) and 'Cooling Setpoint' (K8). The default state is OFF.

W37 'Pushbutton TETS KO 1=Fitted', this switch when set to ON allows the control to utilise the override pushbutton operation of the TB/TS/KO range of thermistor room temperature sensors. The default state is OFF.

W39 'Fan Speed Select 1=Remote', this switch when set to ON forces the strategy to use the value from knob 'Remote Fan Speed' (K15) and not sensor 'Local Fan Speed' (S27). The default state is OFF.

Knobs Switches >41

Options

W41 'Window Mode 1=Enabled', this switch when set to ON forces the control to treat the digital input 'Window Pushbutton PIR' (I24) as a window contact.

W42 '0=Pushbutton 1=PIR', this switch is only used when switch 'Window Mode 1=Enabled' (W41) is set to OFF. Then the switch when set to ON treats the digital input 'Window Pushbutton PIR' (I24) as a passive infrared detector and when set to OFF treats the input as a pushbutton. The default state is OFF.

W45 'Fan Off at Setpoint 1=Enabled', this switch when set to ON will disable the fan when the unit is at setpoint and there is no heating or cooling demand. The default state is OFF.

Energy

K51 'ECO Mode Deadband Increase', this knob defines the value that will be added to the existing deadbands when switch 'Operating Mode 0=Comfort 1=ECO' (W51) is set to ON. The default value is 3°C or 7°F.

K52 'Power Conversion Factor', this knob defines the scaling factor that will be multiplied with the heat meter module output to produce kW. 1kW = 0.948608 Btu/s. The default value is 1 when using kW and 0.948608 when using Btu/s.

W51 'Operating Mode 0=Comfort 1=ECO', this switch when set to ON enables the control to operate in eco mode and increase the deadband by the value on knob 'ECO Mode Deadband Increase' (K51). The default state is ON.

W52 'Energy Meter 1=Reset', this switch when set to ON will reset the energy meter. Once set the control automatically resets the switch to OFF. The default state is OFF.

Window PushbuttonPIR Operation

The external digital Input 'Window Pushbutton PIR' can be used as either a window contact, PIR or Override Pushbutton and its type configured by Switches '0=Pushbutton 1=PIR' and 'Window Mode 1=Enabled'.

In window mode (Switch 'Window Mode 1=Enabled' set to ON) the Input 'Window Pushbutton PIR' is configured to be a window contact. When the window contact is open the control will override the unit into Unoccupied.

In pushbutton mode (Switch '0=Pushbutton 1=PIR' set to OFF) the Input 'Window Pushbutton PIR' forces the unit into Bypass from any state for the time set ON Knob 'Pushbutton PIR Timeout'.

In PIR mode (Switch '0=Pushbutton 1=PIR' set to ON) the Input 'Window Pushbutton PIR' will override the unit from Occupied or Standby into Bypass for at least the time set ON Knob 'Pushbutton PIR Timeout'.

Within the unit, the Bypass condition is treated the same as Occupied so that although Sensor 'Occupancy' shows separate Occupied and Bypass states, if Bypass is set then Inputs 'Unit In Bypass' and 'Unit Occupied' will both be set to ON.

The Switch 'Unit Bypass Request 1=Active' can be used to stop or start the bypass condition.

When Switch 'Pushbutton TETS KO 1=Fitted' is set to ON the external Sensor 'Local Setpoint Adjust' out of limits alarm is used to as the input for PIR or pushbutton override.

Technical Description

A single external digital Input 'Window Pushbutton PIR' is used as a window contact, PIR or Override Pushbutton to create a 'PB PIR override active' and 'Unit interrupt' digital signals. When used as a PIR or Pushbutton the input is only processed by the strategy at the rate of the counter module reschedule time. This is to ensure that only one press of the button is reacted to by the strategy.

The strategy also supports the use of a TE/TS/KO for the override pushbutton using external Sensor 'Local Setpoint Adjust' and Switch 'Pushbutton TETS KO 1=Fitted'.

Commissioning Details

1. Configure strategy for the type of Input connected to Input 'Window Pushbutton PIR' using Switches 'Window Mode 1=Enabled' and '0=Pushbutton 1=PIR'.
2. If override is provided by TB/TS/KO set Switch 'Pushbutton TETS KO 1=Fitted' to 1.
3. Set the time of Knob 'Pushbutton PIR Timeout' for the length of the bypass period required.

Tip.

Input 'Window Pushbutton PIR' can be configured as a status monitoring input e.g. filter dirty by changing the E parameter on function module 'Input active' to 100 and setting Switch 'Window Mode 1=Enabled' to 0. Remember to change the label on the input to indicate its function.

Occupancy State

The unit operates in either Occupied, Unoccupied, Bypass, and Standby modes as determined by the 'Remote Occupancy' setting.

Occupied: The unit is on for normal operation and controls to a user defined setpoint. This is Comfort mode as defined in the European standard EN15500.

Unoccupied: The unit is off, no fan, heating or cooling. The PIR has no effect although the override pushbutton will override the unit into bypass. This is Building Protection mode as defined in the European standard EN15500.

Bypass: The unit has been put into occupation by the override pushbutton or the PIR (occupancy sensor).

Standby: The unit is activated to reduce its energy consumption. In this mode either the override pushbutton or the PIR will put the unit back into occupied. This is Economy mode as defined in the European standard EN15500.

Within the unit the Bypass condition is treated the same as Occupied but both inputs 'Unit In Bypass' and 'Unit Occupied' will be set to ON.

When Switch 'Remote Shutdown 1=Shutdown' is set to ON it will override the unit into unoccupied. The same behaviour occurs if the unit is in window mode (Switch 'Window Mode 1=Enabled' set to ON) and the window contact on Input 'Window Pushbutton PIR' is not closed.

Technical Description

A single external digital Input 'Window Pushbutton PIR' is used as either a window contact, PIR or Override Pushbutton. The required occupancy states are decoded to digital signals. 0 = Occupied, 1 = Unoccupied, 2 = Bypass, 3 = Standby. The unit can also be put in to occupancy using the service pin.

Discharge and Space Temp**Technical Description**

With external sensor 'Local Discharge Air Temp' fitted the sensor value is gated through to internal sensors 'Discharge Air Temperature'. The internal sensor 'Space Temperature' will use the value of either the external sensor 'Room Display Space Temp', when a Room Display module is fitted, or the value from external sensor 'Local Space Temperature', if fitted. If the external sensor has a 'Read' or 'Out of limit' alarm the value of input F on the respective gate module will be displayed on the internal sensor.

Setting switch 'Temperature Select 1=Remote' to 1 forces the internal sensor 'Space Temperature' to use the value on input F of the gate module 'Actual space temperature'.

Heating Cooling Setpoints

The heating and cooling setpoints can be configured to be separately adjusted or calculated. The selected setpoints have half the current deadband applied as defined by the occupation state. The value of the deadband is increased when not in occupation. The setpoint can also have an offset (trim) adjustment made locally, that will increase or decrease the required setpoint.

Eco Features

Local offset adjustment is valid for an adjustable time after which it is ignored until a change of the offset value is detected. The size of the deadband is increased when the unit is in ECO mode.

Technical Description

The setpoint is calculated from Knob 'Remote Setpoint' unless Switch 'HeatCool Setpoint 1=Separate' is set to 1 when Function 'Selected heat setpoint' and Function 'Selected cool setpoint' use Knobs 'Heating Setpoint' and 'Cooling Setpoint' respectively for their values.

The 'Heat setpoint' is calculated by subtracting half the deadband, selected by the mode of occupation, from the value on Function 'Selected heat setpoint' and adding any value on Function 'Setpoint offset'. The 'Cool setpoint' is calculated by adding half the deadband, selected by the mode of occupation, to the value on Function 'Selected cool setpoint' and adding any value on Function 'Setpoint offset'. The 'Heat setpoint' and 'Cool setpoint' are each halved and combined to provide the 'Setpoint'.

FCU EC Fan WR4

The normal operation of 'Setpoint offset' with the external Sensor 'Local Setpoint Adjust' fitted is for the sensor value to be gated through Function 'Selected setpoint offset' and the value of Knob 'Offset Range' to be gated through Function 'Selected offset range'. If the sensor has a 'Read' or 'Out of limit' alarm or Switch 'SP Offset Select 1=Remote' is set to 1 the strategy gates through the value of Knob 'Remote Setpoint Offset' on Function 'Selected setpoint offset' and a value of 1 through Function 'Selected offset range'.

If a Room Display module is fitted the strategy will automatically use the value on Knob 'Room Display Setpoint' to calculate any change in setpoint and feed this through as the offset value.

Any change in the offset value is detected by the strategy and will start Logic timer 'Adjustment active'. The offset value on Function 'Selected setpoint offset' is gated through Function 'Active setpoint offset' it is then scaled using the value on Function 'Selected offset range'. Function 'Setpoint offset' value is added to the 'Minimum setpoint' and 'Maximum setpoint' to provide the 'Heat setpoint' and 'Cool setpoint' respectively and is set to 0 after the time set on Knob 'Setpoint Adjust Timeout' has expired.

Heating Cooling Demands

Heating and cooling demands are calculated by comparing the space temperature with the relevant setpoint. If the space temperature is below the heating setpoint a heating demand is created and if the space temperature is above the cooling setpoint a cooling demand is generated, the greater the difference the larger the demand. To prevent hunting of the heating and cooling demands a deadband is employed to ensure a change equal to half the deadband is detected before a demand is generated or removed. When the heating or cooling demand reaches 100% the speed of the fan is increased. When a frost condition exists and the unit state is unoccupied the heating is enabled.

Technical Description

Both heating and cooling sides are controlled by different control loops. Heating and cooling loops are enabled whenever 'Unit interrupt' and 'Fan control off selected' are set to 0.

The heating loop compares the "Actual space temperature" with the "Heating setpoint". The proportional + integral (P+I) loop will modulate the heating output to maintain a constant space temperature. As the temperature decreases below the heating setpoint the heating output will modulate open. The heating output will be modulated closed as the temperature increases above the heating setpoint. The loop output is limited to the range 0 to 100%.

The cooling loop compares the "Actual space temperature" with the "Cooling setpoint". The proportional + integral (P+I) loop will modulate the cooling output to maintain a constant space temperature. As the temperature increases above the cooling setpoint the cooling output will be modulated open. The cooling output will be modulated closed as the temperature decreases below the cooling setpoint. The loop output is limited to the range 0 to 100%.

Error, $E = \text{setpoint} - \text{Space Temp}$

$$\text{LoopOutput} = G(E) + \int \frac{G(E)}{I} .dt$$

Where $G = \text{Loop gain}$

$I = \text{Integral time constant}$

The integral time constant is the time for which the loop output will have added to it an amount equal to product of the error and the gain (i.e. equal to the proportional part) under conditions of constant error. If the error stays the same for the integral time constant, the loop output will double and will be $2G(E)$. The loops have the following default settings: heat loop gain = 20, cool loop gain = -20, both loop integral time constants = 10 minutes. These settings can be changed by text comms.

The output from the loops (ignoring the integral action) is illustrated by the chart below:

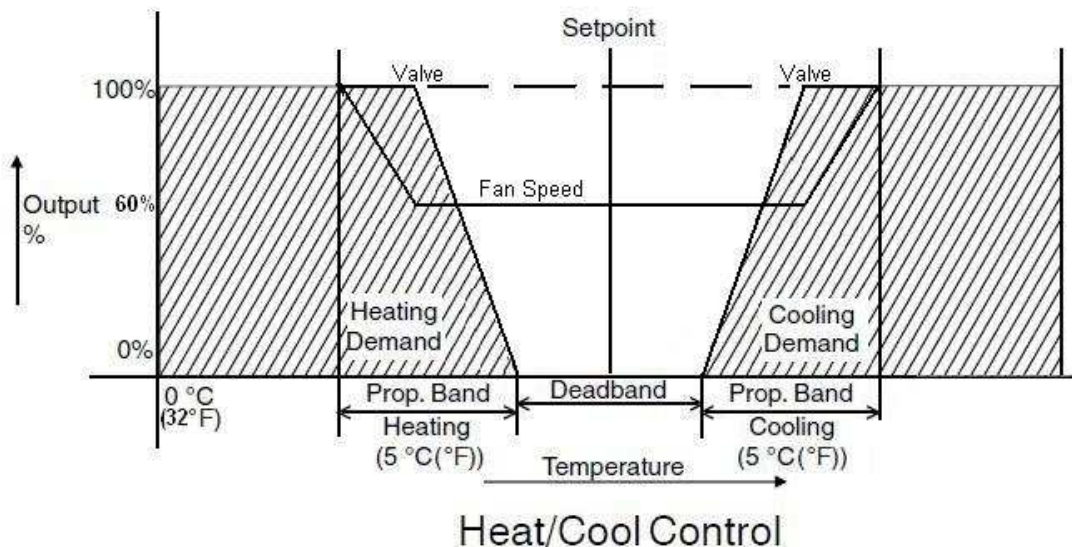

The heating loop will not operate until the 'Actual space temperature' drops below the 'Heating setpoint' by half the deadband e.g. Setpoint 22°C (72°F) deadband 4° = 22-2 = 20°C (72-4 = 68°F) during occupation. Similarly for cooling it must rise above the 'Cooling setpoint' by half the deadband. The loop gains are set to ±20 by default which gives proportional bands of 5°C (°F) i.e. 100/20. When set to defaults, during occupation, this will give 100% heat at 15°C (59°F), and 100% cool at 29°C (84°F) ignoring the effect of the integral term.

The loop outputs are added together and then split into separate heating and cooling outputs to prevent simultaneous heating and cooling. The separate demands are rescaled so the demand 0 to 50% drives the relevant valve output between 0 and 100% and the demand 50 to 100% increases the fan speed. When the heating or cooling demand is greater than 4.5% a respective 'Heating required' or 'Cooling required' signal will be set to 1. The 'Heating required' or 'Cooling required' signals are reset to 0 when the respective demand falls below 0.5%.

The heating loop is overridden to 98% if the "Frost Condition 1=Frost" is set to 1 and "Unit - unoccupied" is set to 1. This will bring on the heating.

Heating Cooling Valves

The heating demand drives the heating valve. A demand of 100% opens the valve fully and a demand of 0% closes the valve. The cooling demand drives the cooling valve. A demand of 100% opens the valve fully and a demand of 0% closes the valve. Both the heating and cooling valves are fully opened when Switch 'Water Balance 1=Enabled' is ON.

Technical Description

The heating valve can be overridden, providing Switch 'Overrides 0=Disabled 1=Enabled' is set to 1, by setting switch 'Heating Override 1=Enabled' to 1 and adjusting Knob 'Heating Override Value' to the required value between 100 and 0.

The cooling valve can be overridden, providing Switch 'Overrides 0=Disabled 1=Enabled' is set to 1, by setting switch 'Cooling Override 1=Enabled' to 1 and adjusting Knob 'Cooling Override Value' to the required value between 100 and 0.

Overrides are ignored and the valves are fully opened when Switch 'Water Balance 1=Enabled' is 1.

Commissioning Details

1. The heating valve drive time should be set to match the fitted actuator.
2. The cooling valve drive time should be set to match the fitted actuator.

Fan Control - Variable Speed

The fan is ON when the occupation state is occupied; bypass or standby and is OFF when unoccupied. The required speed of the fan is displayed on the sensor 'Selected Fan Speed' where 0 = OFF, 1 = Low, 2 = Medium, 3 = High and 4 = Auto. Low speed is the value set on knob 'Minimum Fan Speed Setpoint' and High speed is the values set on knob 'Maximum Fan Speed Setpoint'. Medium speed is the mid value between these two setpoints. If the 'Selected Fan Speed' is Auto, the fan will normally run at low speed, but as the fan demand increases, as a result of an increase in the heating or cooling demand, the fan speed will be increased to meet the demand, similarly the fan speed will be reduced as demand is met. The actual fan speed is displayed on the sensor 'Actual EC Fan Speed' and is a factor of 10 smaller than the demand i.e. Low = 'Minimum Fan Speed Setpoint' = 37 will display as 3.7. The fan has an anti cycling timer to protect it from excessive restarts.

Eco Features

The fan can be set to switch OFF whenever the unit is at setpoint i.e. no heating or cooling demand by setting Switch 'Fan Off at Setpoint 1=Enabled' to ON. The fan will restart when a heating or cooling demand exists. This is only applicable when the sensor 'Selected Fan Speed' is set to Auto (a value of 4).

Technical Description

The fan is enabled when the occupation state is occupied, bypass or standby and the unit interrupt signal is 0. The driver 'Occupation Relay' is enabled during occupation, time delayed based on the controller address, and is intended to be used to enable the fan controller.

Automatic control is achieved by rescaling the fan demand set between the 'Minimum Fan Speed Setpoint' to the 'Maximum Fan Speed Setpoint'. When the required to switch off the 'Minimum Fan Speed Setpoint' value is replaced with 0.

The fan control can only be overridden when Logic 'Unit - unoccupied' is 0 by either Knob 'Remote Fan Speed' or the WMB Room Display module. The strategy selects the correct control depending on which items are present using the WMB Room Display module 'I/O2 Failed status' bit.

The Knob 'Remote Fan Speed' is used when its value is less than 4 or when Switch 'Fan Speed Select 1=Remote' is set to 1. When used the knob has precedence over the external WMB Room Display module.

The WMB Room Display module if fitted uses Knob 'Room Display Fan Speed' to display and adjust the speed.

The fan control has an anti cycling timer that delays the time to restart after the fan stops thus preventing unwanted cycling of the fan. When electric heaters are included in the control the fan will run when Logic 'Electric heat run on required' is 1.

The fan control can be overridden, providing Switch 'Overrides 0=Disabled 1=Enabled' is set to 1, by setting Switch 'Fan Override 1=Enabled' to 1 and adjusting Knob 'Fan Speed Override Value EC' to the required value. The anti cycle timer still operates under these circumstances.

Commissioning Details

1. Set the 'Minimum Fan Speed Setpoint'
2. Set the 'Maximum Fan Speed Setpoint'
3. Confirm that Comparator 'Fan enabled' parameter E value is correctly set to indicate that the fan is enabled.
4. The Timer 'Anti cycle active' parameter F requires setting to ensure the minimum off time required for anti cycling the fan. 300 seconds = 5 minutes = 12 starts per hour.
5. The switch 'Fan Speed Select 1=Remote' requires setting to 1 if the WMB Room Display is to be excluded from the control of the fan.

Service Button - Water balance

Pressing the service button in a predefined sequence, when in service button mode, can initiate behaviour in the strategy to start and stop water balancing where all the valve outputs are set to 100% or 0% i.e. fully open or fully closed. The function is only available if Switch 'Service Button Mode 1=Enabled' is set to ON. For a full description of service pin mode refer to the Trend publication TE201089 IQeco Configuration Manual Issue 2 or greater. The service button press sequence for the required behaviour is as follows;

Required Action	Phase 1	Phase 2	Phase 3
Water Balance On for the Lan	No Press	No Press	No Press
Water Balance Off for the Lan	Press	No Press	No Press
Water Balance On for the Unit	No Press	Press	No Press
Water Balance Off for the Unit	Press	Press	No Press

Technical Description

The service button can be used to initiate behaviour designed in the strategy; to achieve this behaviour the controller must be put into service button mode. Service button mode has 5 stages Entry, Phase 1, Phase 2, Phase 3 and Exit.

Entry - Press and hold the service button for 2 to 5 seconds. When the service button is released a rapidly flashing comms LED (green) for one second indicates entry into 'service button mode'. When the flashing stops this indicates the start of Phase 1.

Phase 1 - This stage lasts 3 seconds and during this time if the service button is not pressed it will mean that a ON condition is required. If it is pressed then an OFF condition is required. At the end of this stage the comms LED (green) will flash once to confirm no press and twice to confirm a press. The end of the flashing indicates the start of phase 2.

Phase 2 - This stage lasts 3 seconds and during this time if the service button is not pressed it will mean that the selection in Phase 1 should be applied to the LAN and if it is pressed then it will be applied to the UNIT. At the end of this stage the comms LED (green) will flash once to confirm no press and twice to confirm a press. The end of the flashing indicates the start of phase 3.

Phase 3 - This stage lasts 3 seconds and during this time if the service button is not pressed it will mean that a Water Balance selection is required and if it is pressed then it will indicate that an Occupancy selection is required. At the end of this stage the comms LED (green) will flash once to confirm no press and twice to confirm a press. The end of the flashing indicates the start of the Exit stage.

Exit - This stage lasts for 3 seconds and starts with a rapidly flashing comms LED (green). During this stage if the service button is not pressed then the service button mode will expire without any further action. The service button must be pressed to confirm the selections made in phases 1, 2 and 3. Once pressed the LED will go out for the remainder of the stage and the virtual input channel selected by the choices made during phases 1, 2 and 3 will go ON for one pass of the sequence table. The virtual input channel is allocated to a Digital Input module to make it available to be used by the strategy. At the end of this stage the service button mode will be automatically exited and the LED and service button return to their normal operation.

Service Button - Occupancy

Pressing the service button in a predefined sequence, when in service button mode, can initiate behaviour in the strategy to change the occupancy state to occupied or unoccupied. The function is only available if Switch 'Service Button Mode 1=Enabled' is set to ON. For a full description of service pin mode refer to the Trend publication TE201089 IQeco Configuration Manual Issue 2 or greater. The service button press sequence for the required behaviour is as follows;

Required Action	Phase 1	Phase 2	Phase 3
Occupied for the Lan	No Press	No Press	Press
Unoccupied for the Lan	Press	No Press	Press
Occupied for the Unit	No Press	Press	Press
Unoccupied for the Unit	Press	Press	Press

Technical Description

The service button can be used to initiate behaviour designed in the strategy; to achieve this behaviour the controller must be put into service button mode. Service button mode has 5 stages Entry, Phase 1, Phase 2, Phase 3 and Exit.

Entry - Press and hold the service button for 2 to 5 seconds. When the service button is released a rapidly flashing comms LED (green) for one second indicates entry into 'service button mode'. When the flashing stops this indicates the start of Phase 1.

Phase 1 - This stage lasts 3 seconds and during this time if the service button is not pressed it will mean that an ON condition is required. If it is pressed then an OFF condition is required. At the end of this stage the comms LED (green) will flash once to confirm no press and twice to confirm a press. The end of the flashing indicates the start of phase 2.

Phase 2 - This stage lasts 3 seconds and during this time if the service button is not pressed it will mean that the selection in Phase 1 should be applied to the LAN and if it is pressed then it will be applied to the UNIT. At the end of this stage the comms LED (green) will flash once to confirm no press and twice to confirm a press. The end of the flashing indicates the start of phase 3.

Phase 3 - This stage lasts 3 seconds and during this time if the service button is not pressed it will mean that a Water Balance selection is required and if it is pressed then it will indicate that an Occupancy selection is required. At the end of this stage the comms LED (green) will flash once to confirm no press and twice to confirm a press. The end of the flashing indicates the start of the Exit stage.

Exit - This stage lasts for 3 seconds and starts with a rapidly flashing comms LED (green). During this stage if the service button is not pressed then the service button mode will expire without any further action. The service button must be pressed to confirm the selections made in phases 1, 2 and 3. Once pressed the LED will go out for the remainder of the stage and the virtual input channel selected by the choices made during phases 1, 2 and 3 will go ON for one pass of the sequence table. The virtual input channel is allocated to a Digital Input module to make it available to be used by the strategy. At the end of this stage the service button mode will be automatically exited and the LED and service button return to their normal operation.

Virtual Energy Meter

An estimation of the unit’s energy consumption is calculated by the controller and can be viewed on Sensor ‘Unit Energy Meter’. The consumption is measured over a 30 minute period starting from 0 and increasing until the end of the period when the value is stored in the controller. The controller stores the last 200 values and these can be viewed from suitable displays or supervisory software e.g. IQView and 963. The calculation totals the estimated energy used by the heat exchangers and the energy consumed by the fan and by the loads switched by the relay output. The accuracy of the calculation depends on the values configured in the controller however the default values supplied provide for a like for like comparison between similar units.

Technical Description

The estimated calculations use the heat meter module for the power being provided by the heat exchangers. This power is then added to the power of the fan and using an integrator module the power consumed is calculated over the period of 15, 30 (default) or 60 minutes depending on the configuration of the strategy.

Heat exchanger power estimation formula.

Heating Power = (Heating medium temperature - Space temperature) * Coil duty * Valve position / 100

Power kW (D) = (Water Supply Temp DegC (E) - Space Temp DegC (F)) * Coil Duty kW/degK (G) * Valve Position %(0-100)(H) * 0.01 (constant)(I)

Power Btu/s (D) = (Water Supply Temp DegF (F) - Space Temp DegF (E)) * Coil Duty Btu/sDegF (G) * Valve Position %(0-100)(H) * 0.01 (constant)(I)

Cooling Power = (Space temperature - Cooling medium temperature) * Coil duty * Valve position / 100

Power kW (D) = (Space Temp (E) - Water Supply Temp (F)) * Coil Duty kW/degK (G) * Valve Position %(0-100)(H) * 0.01 (constant)(I)

Power Btu/s (D) = (Space Temp DegF (E) - Water Supply Temp DegF (F)) * Coil Duty Btu/sDegF (G) * Valve Position %(0-100)(H) * 0.01 (constant)(I)

To improve the accuracy of the estimation the following parameters should be configured with the correct value for the unit:

Function module	Parameter	Units
'Heating coil duty max speed'	F	kW/degK (Btu/sDegF)
'Cooling coil duty max speed'	F	kW/degK (Btu/sDegF)
'Fan duty max speed'	F	kW
'Occupation relay duty'	F	kW

The output 'Occupation Relay' is intended to be the relay that switches the power to the EC fan controller and the value of 'Occupation relay duty' is the duty when the fan controller is energised. The values calculated are linear and therefore are only an estimate.

The period the integrator uses for the calculation can be changed by amending the arguments in parameter K on Logic module 'Meter reset': F = 15 minutes, G = 30 minutes and H = 60 minutes. If the Logic is changed then the period parameter P on plot module 'Unit Energy Meter' should also be changed to match: 1 = 15 minutes, 7 = 30 minutes and 0 = 60 minutes.

Useful conversions:

- 1 kW = 0.948608 Btu/s
- 1 hp = 0.7074163 Btu/s
- 1 Btu/h/3600 = 1 Btu/s

Commissioning Details

1. Set the values of the duty for the coils.
2. Set the values of the duty for the fan.
3. Set the value of the duty for the occupation relay.
4. Confirm the water flow temperatures are received from the main plant.

IC Comms and Alarm Group

Technical Description

The IC Comms are configured for master slave operation directed to standard knobs and switches one or all of the following: Space Temperature, Setpoint, Occupancy and Fan Speed. The IC Comms modules use attribute 3 and to prohibit unwanted communications are, by default, disabled.

FCU EC Fan WR4

One alarm group route and destination modules are configured to send Trend text alarms to address 1 on the local lan, this would normally be the IQ3/BINC VCNC port 10001. To prohibit unwanted alarms the route, by default, is disabled.

Analogue node 99 is provided so a value can be placed in it to indicate the state of the unit during commissioning and witnessing. The meaning of the value is user defined. It is suggested a bit state approach be used where values 1, 2, 4, 8, 16 etc each indicating a separate operation. Summing the values provide a state of the unit.

Suggested values:

1 =	Addressed,
2 =	Attributes Set,
4 =	Pre-commissioned,
8 =	Commissioned,
16 =	Witnessed,
32 =	Backed up,
64 =	(TBC) ,
128 =	Has a Problem.

An example of its use. e.g $11 = 1+2+8 =$ Addressed, Attributes Set and Commissioned.

Digital Input 'Strategy Override 1=Active' when 1 indicates that one of the outputs is being overridden by the strategy and not in normal control.

Commissioning Details

1. For master slave configuration configure attribute 3 and enable IC Comms if master unit.
2. If alarms are required configure alarm destination address and enable alarm route.

Please send any comments about this or any other Trend technical publication to techpubs@trendcontrols.com

© 2011 Honeywell Technologies Sàrl, ECC Division. All rights reserved. Manufactured for and on behalf of the Environmental and Combustion Controls Division of Honeywell Technologies Sàrl, Ecublens, Z.A. La Pièce, 16, 1180 Rolle, Switzerland by its Authorized Representative, Trend Control Systems Limited.

Trend Control Systems Limited reserves the right to revise this publication from time to time and make changes to the content hereof without obligation to notify any person of such revisions or changes.

Trend Control Systems Limited

Albery House, Springfield Road, Horsham, West Sussex, RH12 2PQ, UK. Tel:+44 (0)1403 211888 Fax:+44 (0)1403 241608 www.trendcontrols.com

Trend Control Systems

Albery House,
Springfield Road,
Horsham.
RH12 2PQ

Telephone: +44 (0)1403 211888
Fax: +44 (0)1403 240271
Email: ts@trendcontrols.com

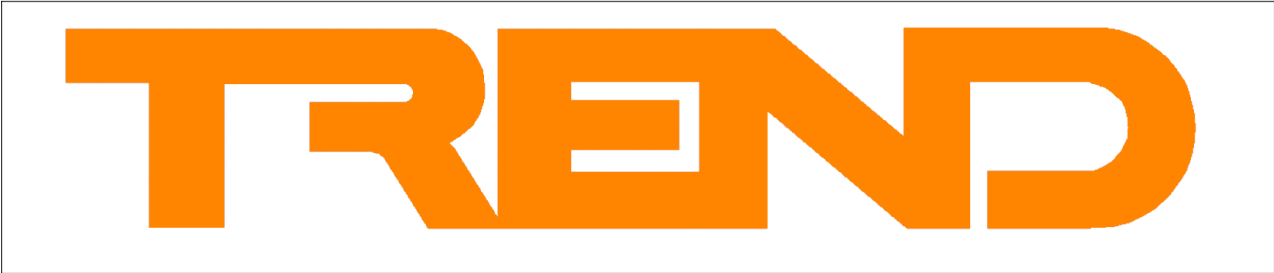

Address Module	
Identifier	
Attribute F	
Attribute G	
Alarm Lan	0
Alarm Address	0
Controller Version	
Serial Number	
Strategy Name	FCU EC Fan WR4
Product Order Code	

Issue	Revision	Project Change Note / Comments	Pages Affected	Date Approved	Approved By
0	1		Page 2, 7, 9, 10, 12 Added new interface to WMB sensors.		
1	0				
2	0				
3	0		Page 2, 7, 9, 10, 12 Added new interface to WMB sensors.		

Notes

The IQeco standard strategy controls a fan coil unit's heat/cool outputs, and electronically commutated fan.

The control responds to a thermistor temperature sensor with a local setpoint knob and a local window contact input and a pushbutton, or Passive Infra Red movement detector input.

The WR4 strategy is for waterside 4 pipe units controlling 2 raise/lower (floating point) valve actuators.

The strategy supports the fitting of a WMB Room display module without further configuration.

Site	
GUID:	{31009522-BE09-4A36-BEC3-9EA8ABCDD52D}
Project:	IQeco_Standard_Strategies_v3.2.1
Client:	
Details:	Fan Coil Unit with EC Fan Waterside 4 Pipes with 2 raise/lower (floating point) Valves.
Drawn By:	Engineer
Engineer:	M Spencer
Controller Type:	IQeco 31
Project Number:	1
Date:	3/24/2016
Outstation: 015	Lan: 019
Page: 01 of 18	

FCU EC Fan WR4

Strategy pages

Title Page	1
WallBus Interface Eco	2
Real Inputs	3
Knobs Switches <21	4
Knobs Switches 21 - 40	5
Knobs Switches >41	6
Window PushbuttonPIR Operation	7
Occupancy State	8
Discharge and Space Temp	9
Heating Cooling Setpoints	10
Heating Cooling Demands	11
Heating Cooling Valves	12
Fan Control - Variable Speed	13
Fan Control - Variable page 2	14
Service Button - Water balance	15
Service Button - Occupancy	16
Virtual Energy Meter	17
IC Comms and Alarm Group	18

Interface module for WMB Displays

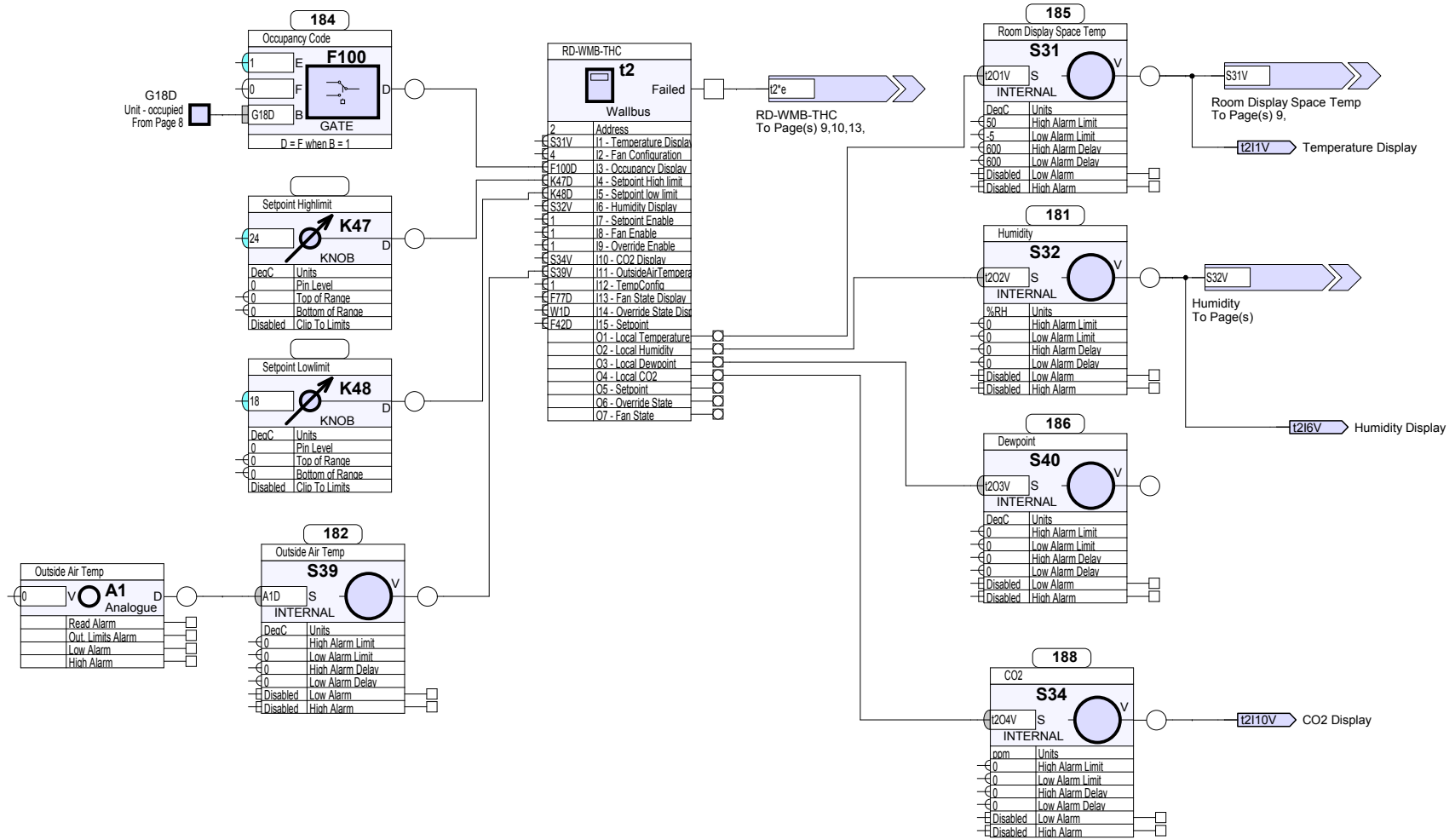

For RS-WMB, RD-WMB refer to Data Sheet TA201348. For RV-WMB refer to Data Sheet TA201354 for more information

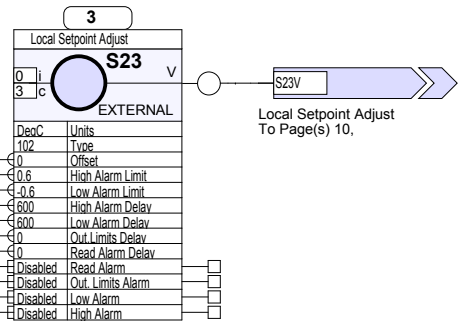
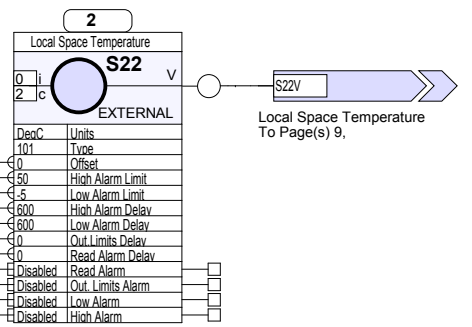
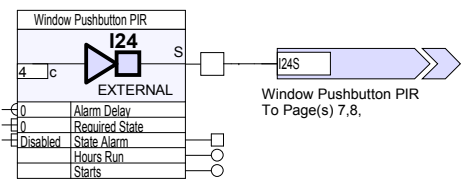
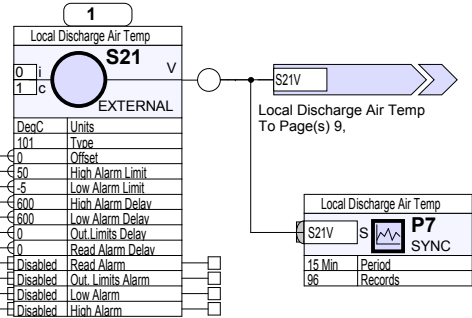

Default Operation

The behaviour of the strategy before any configuration of knobs and switches is as follows:

The default occupancy state of the strategy is unoccupied.

In most cases when the controller is powered on the fan outputs will not operate as the space temperature used for control will be within the deadband for the unoccupied state.

There are 3 ways to take the strategy out of the unoccupied state:

1. Set Knob "Remote Occupancy" (K11) to 0.
2. Using a pushbutton connected to IN4.
Press the pushbutton once; this should place the unit into bypass.
The bypass state is active until another press of the pushbutton or timeouts after 30 minutes.
3. Use the service button to put the unit into occupied.
Details are in "Service Button - Occupancy" section of the strategy datasheet.

The fan output may not be operating for the following reasons:

- a. The fan anti cycling strategy is active. Once switched off the fan will not start for 5 minutes.
- b. Changes to the knobs and switches from the defaults are overriding the fan control.
- c. The occupancy state is unoccupied.

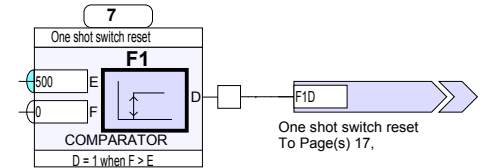

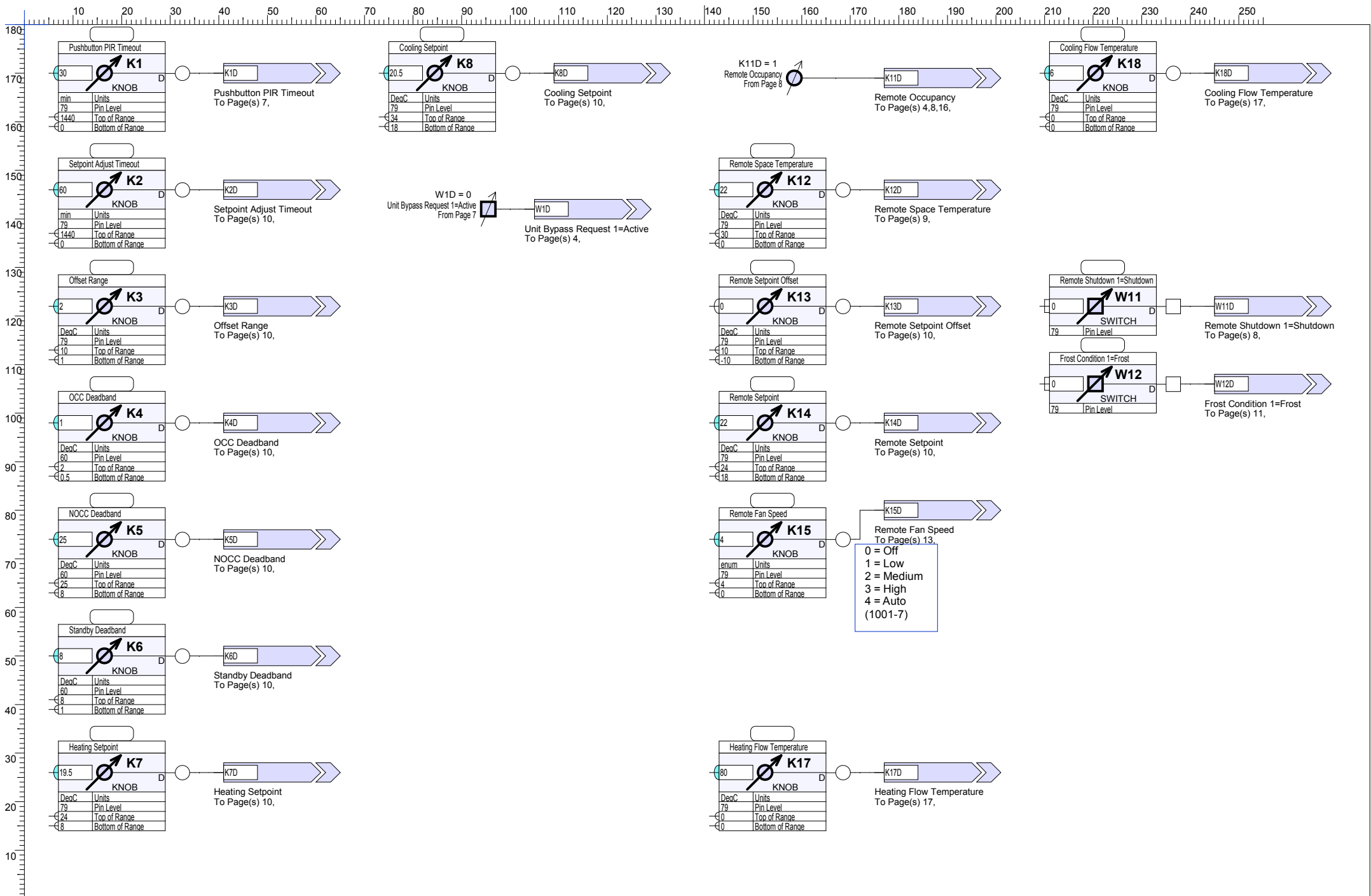

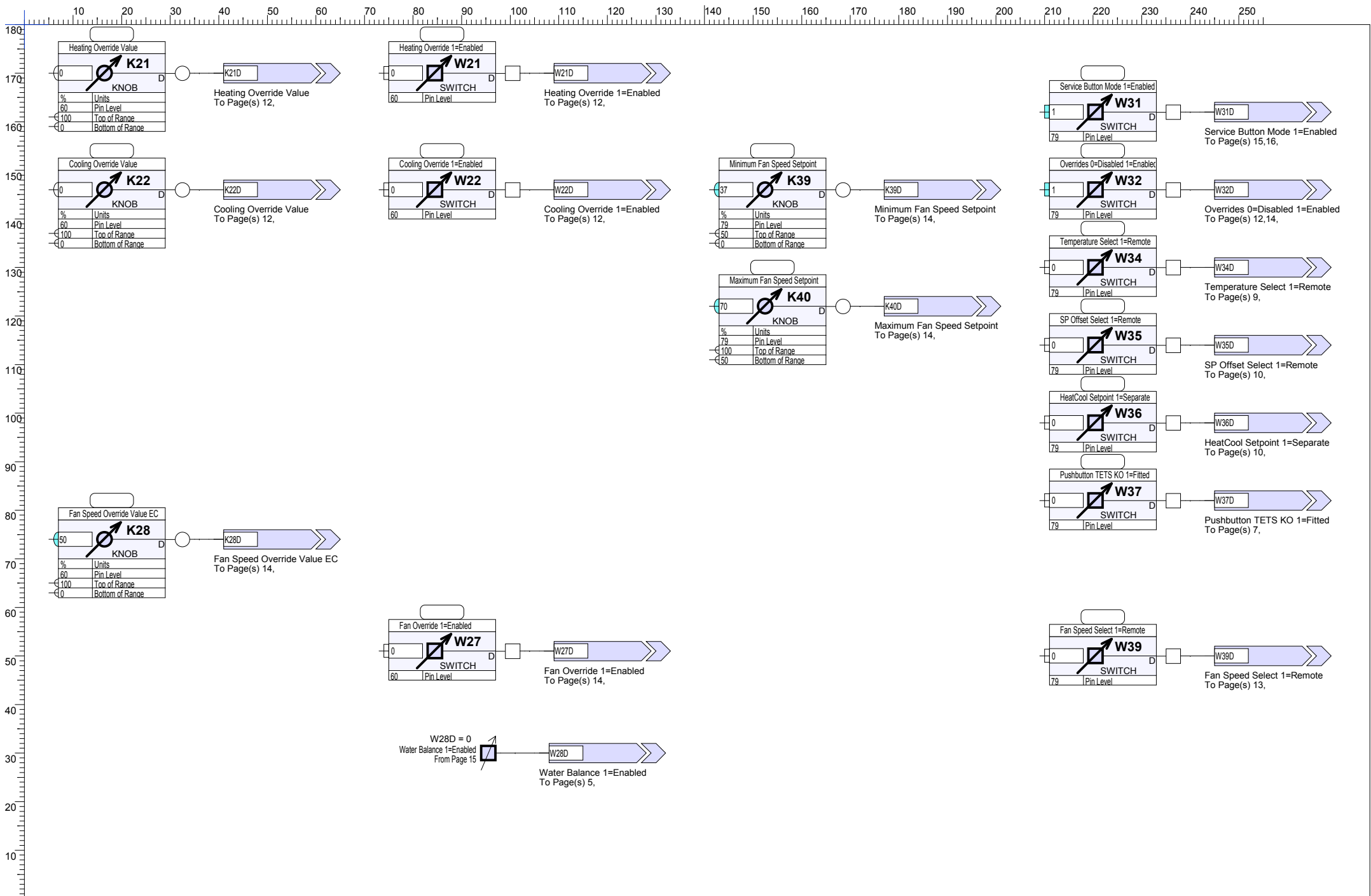

Drawing Reference SET-019-015-05	Page Details Knobs Switches 21 - 40	SET Strategy Designed By:	Trend Control Systems D60D 3201 DA65 8FD9 921A 697A 87	Issue Revision	Checked By	Project Number: 1	Date: 3/24/2016
				3 - 00		Outstation: 015	Page: 05 of 18

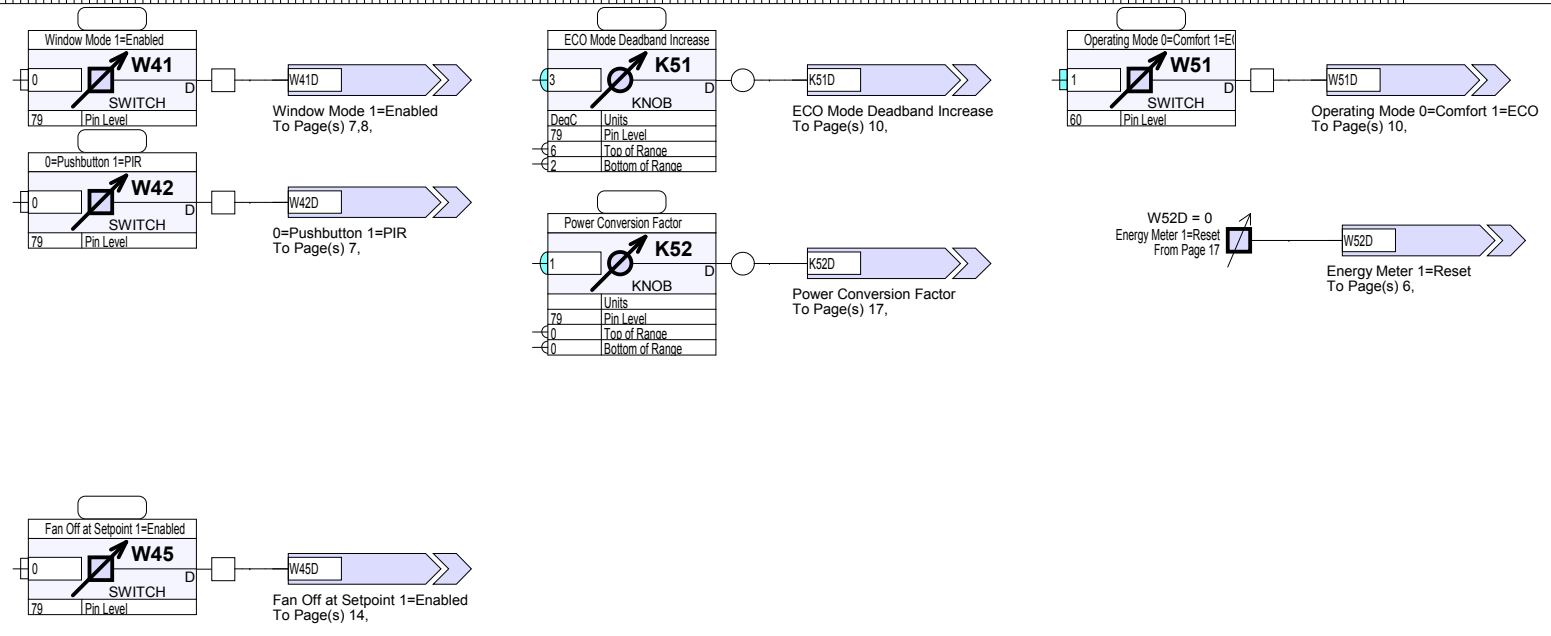

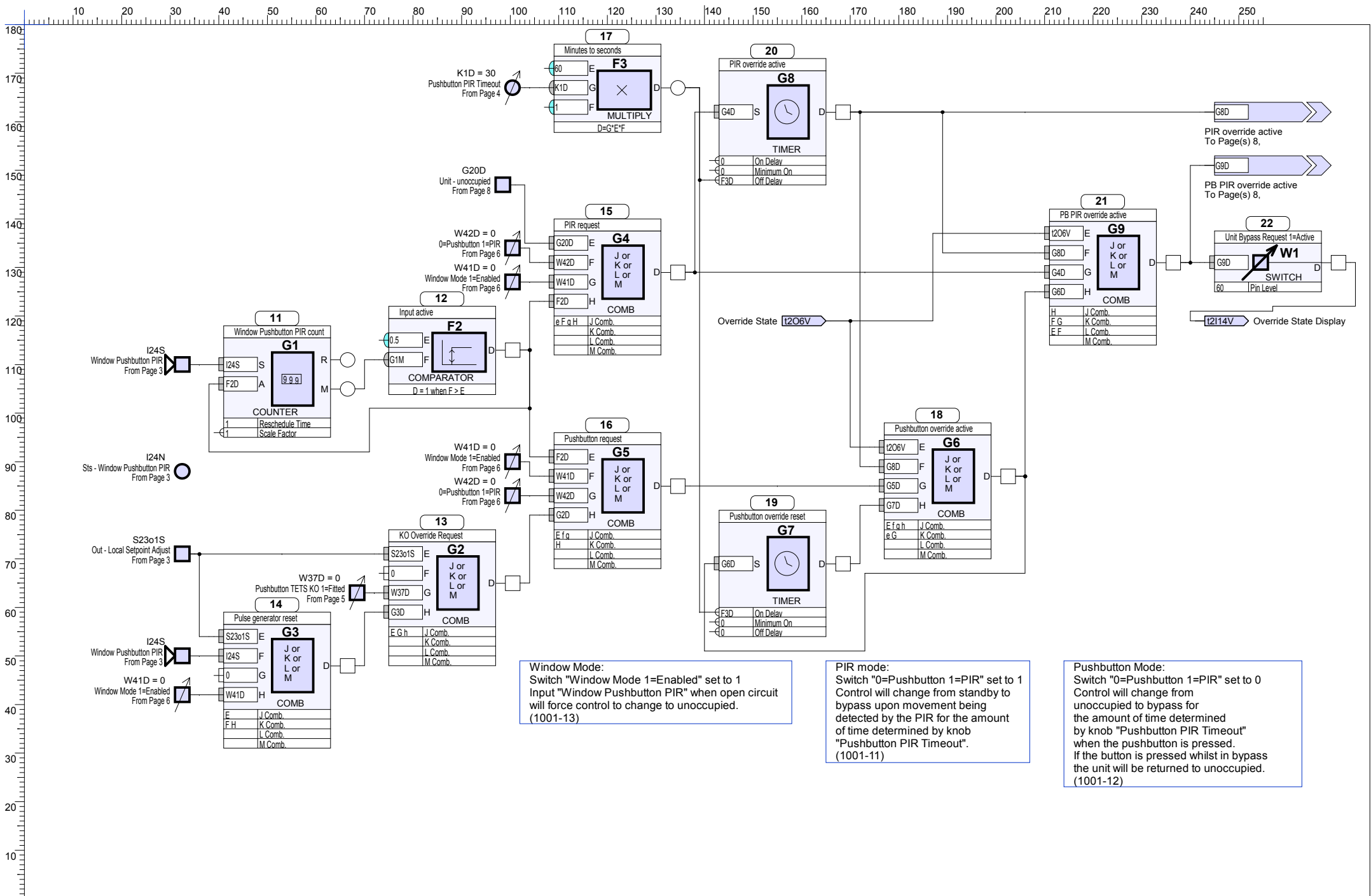

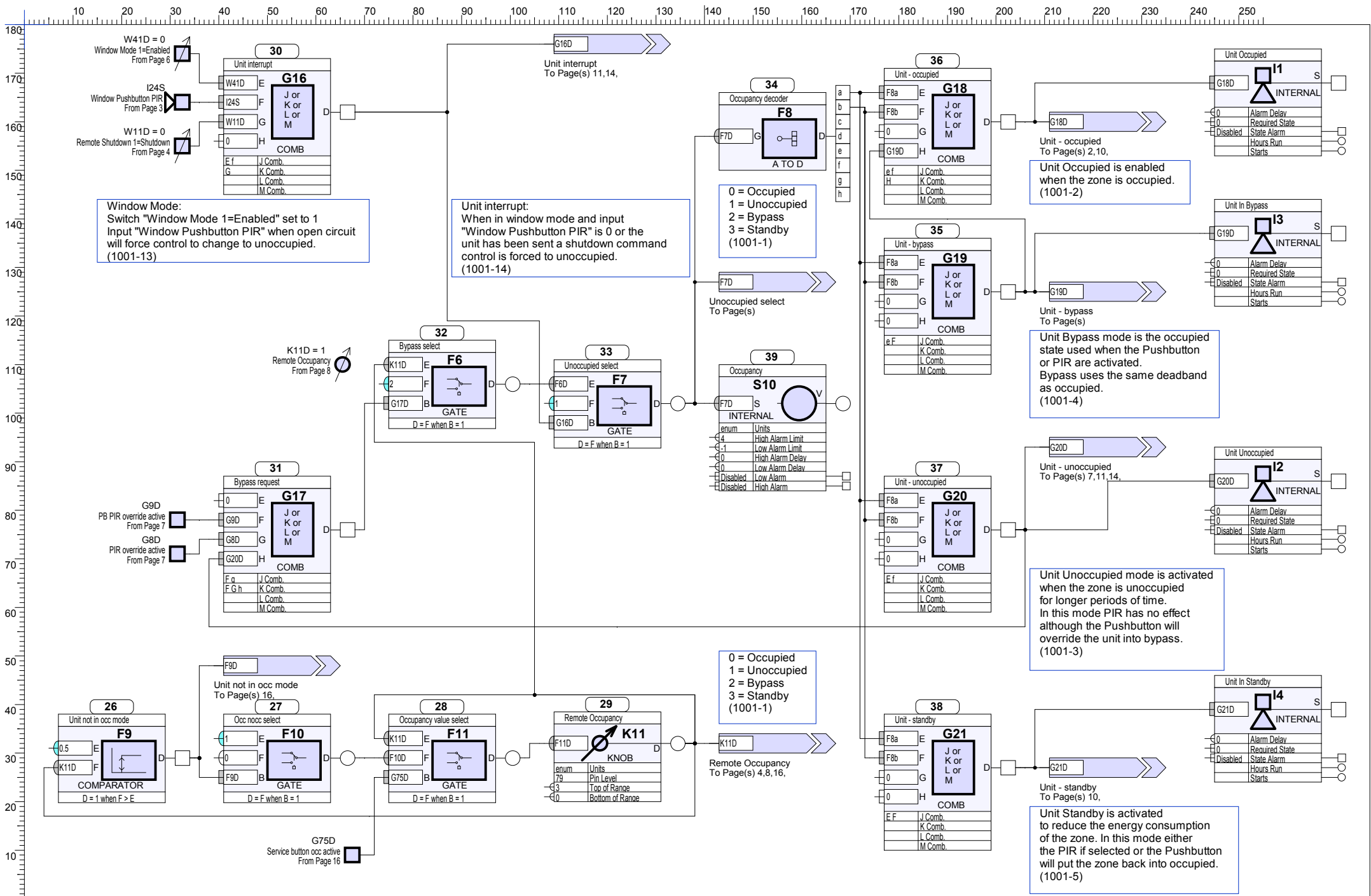

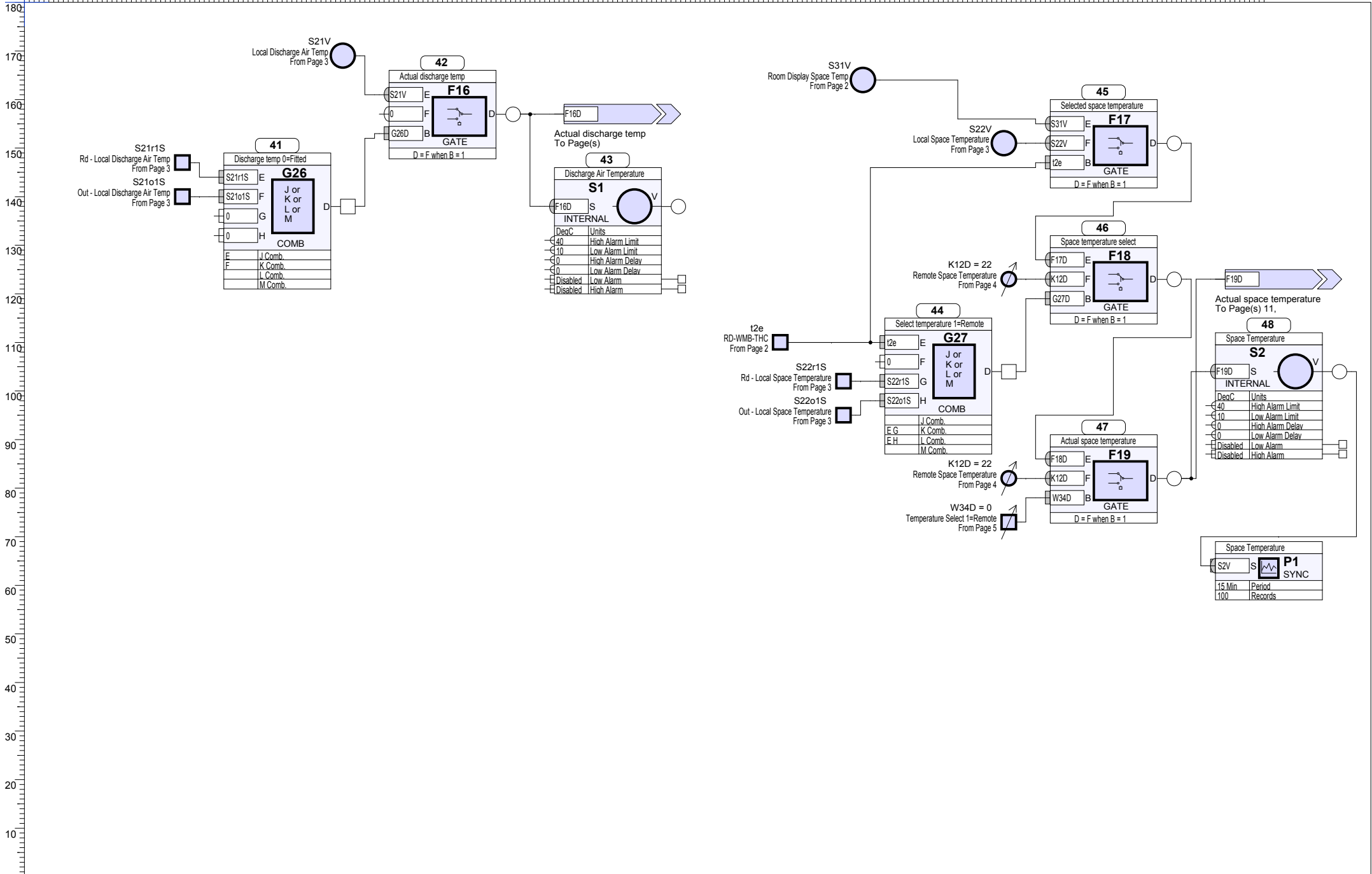

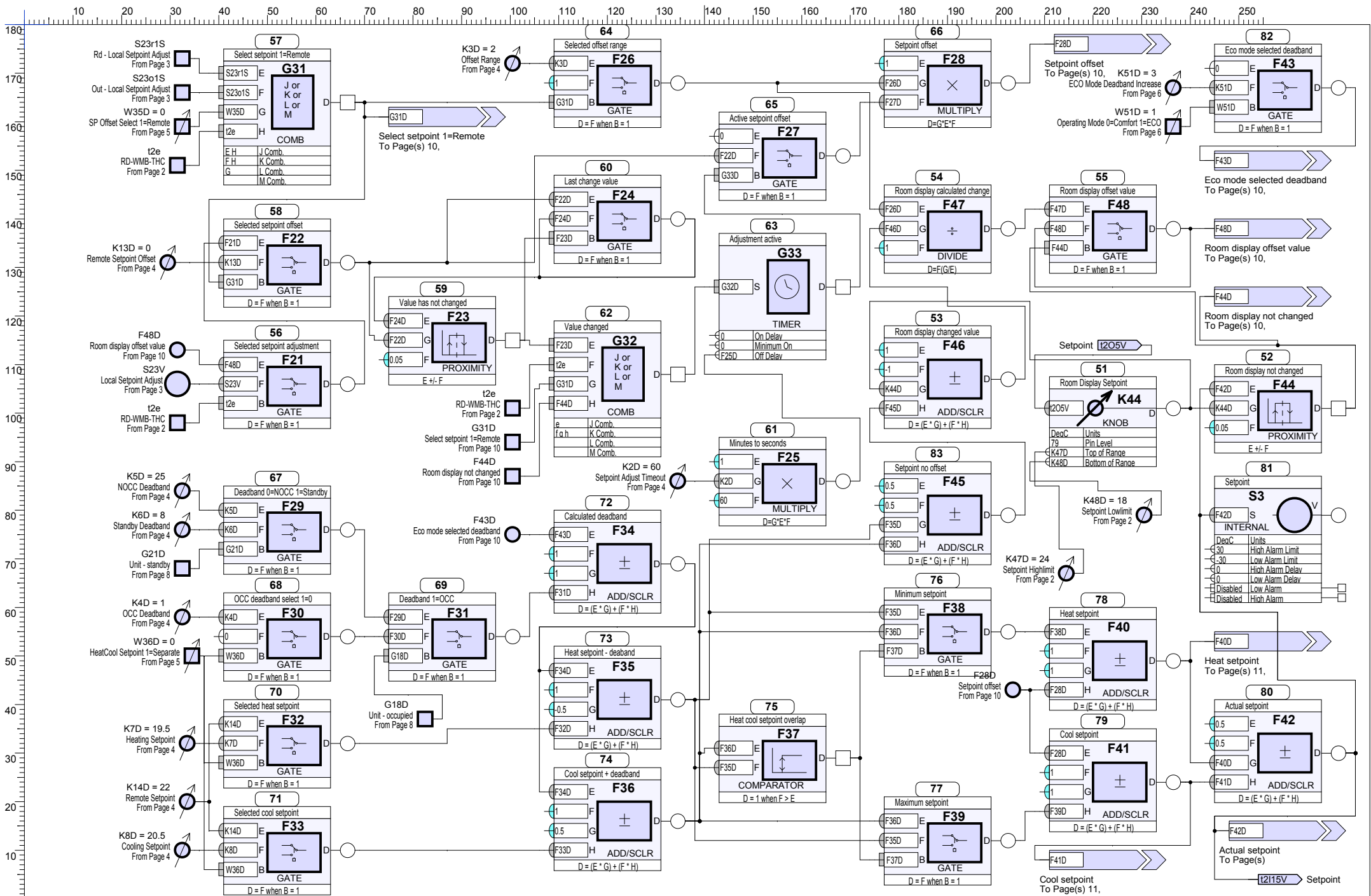

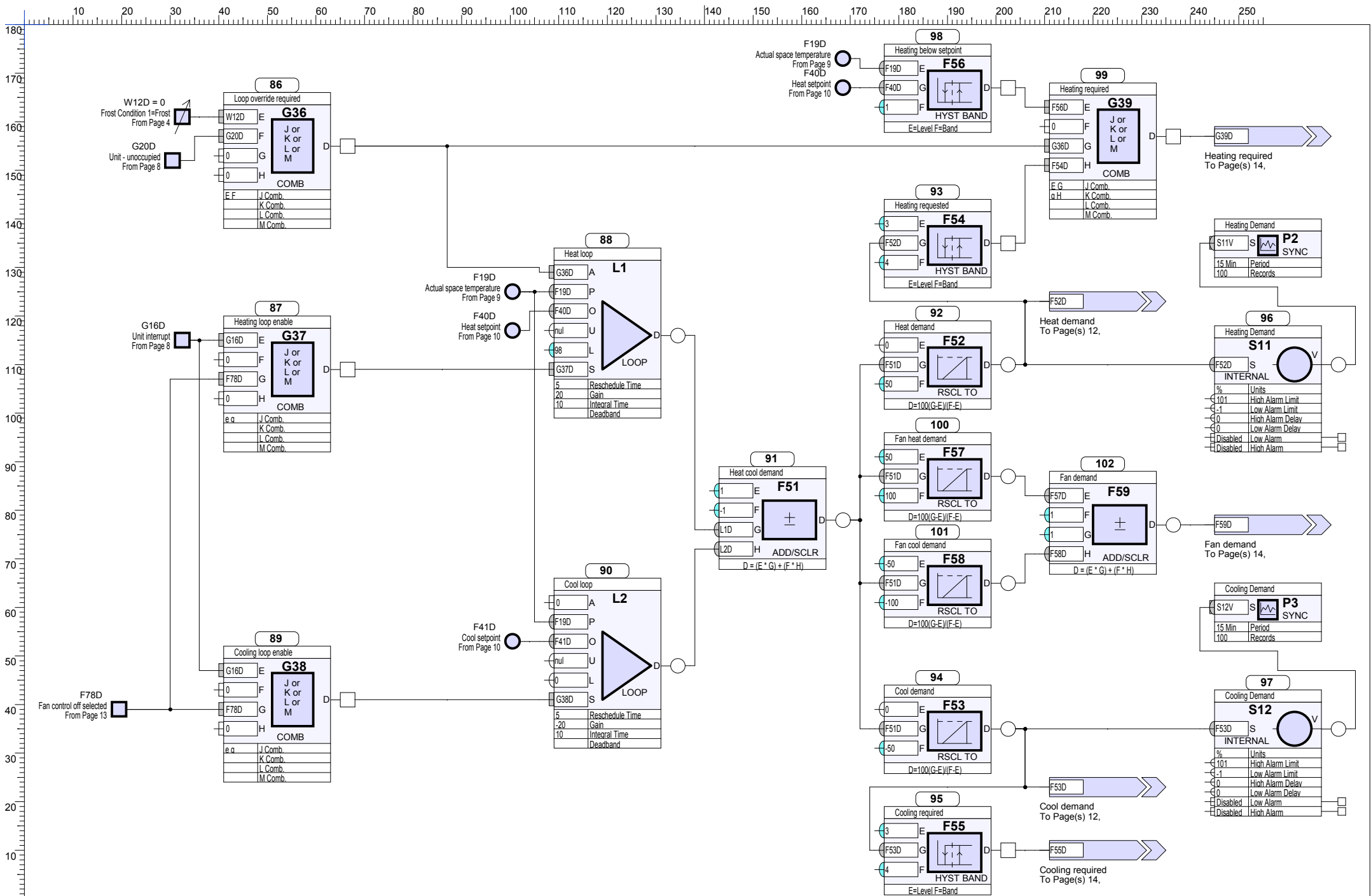

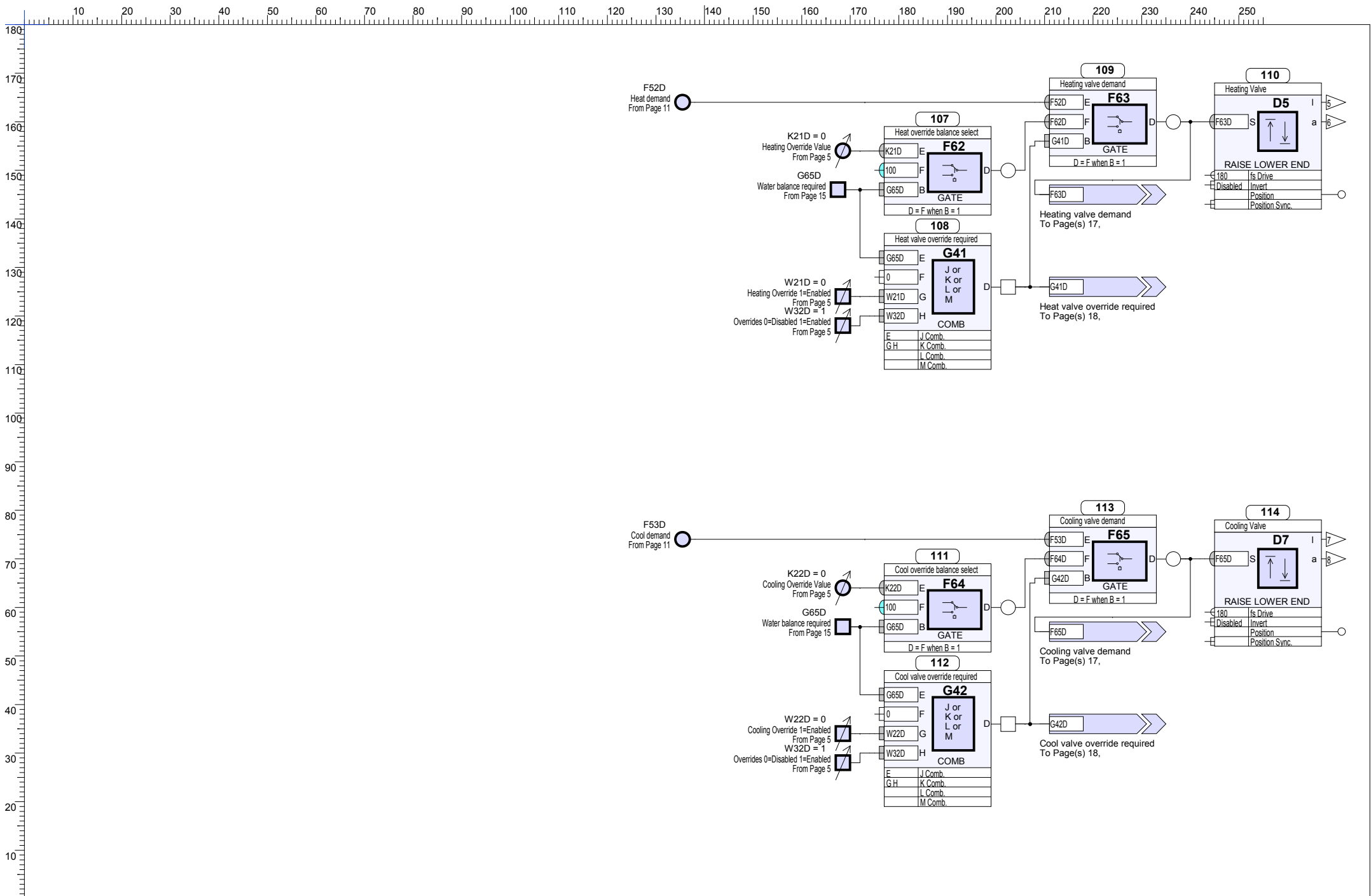

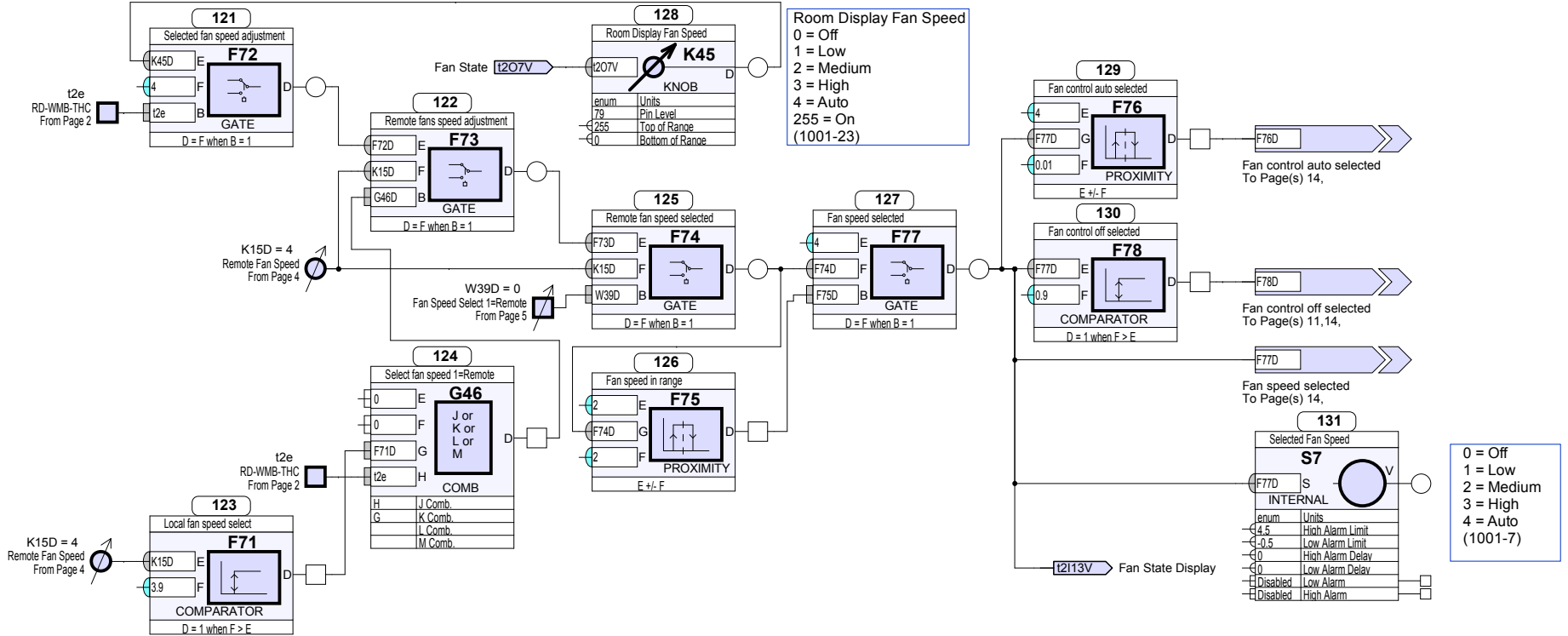

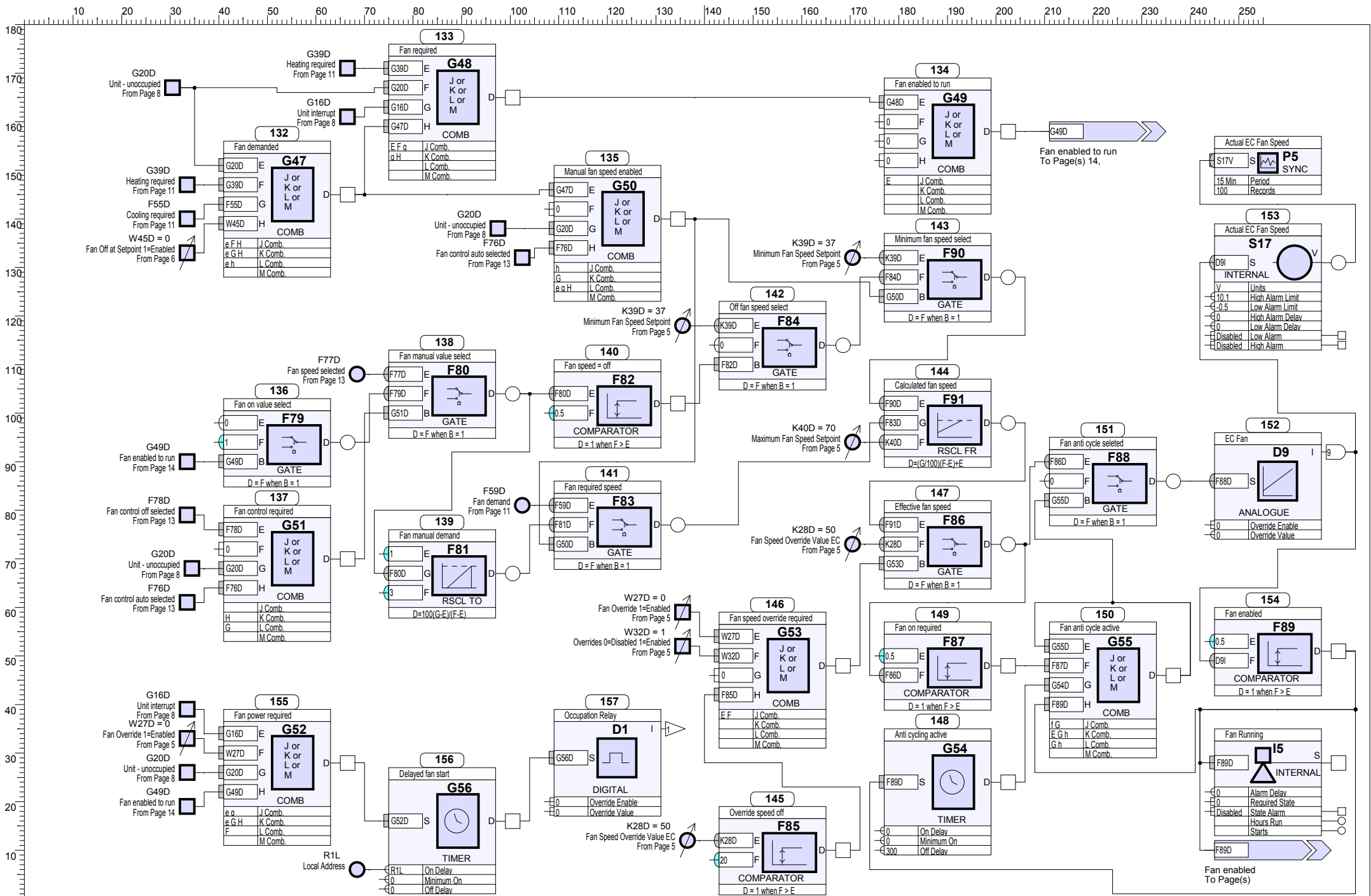

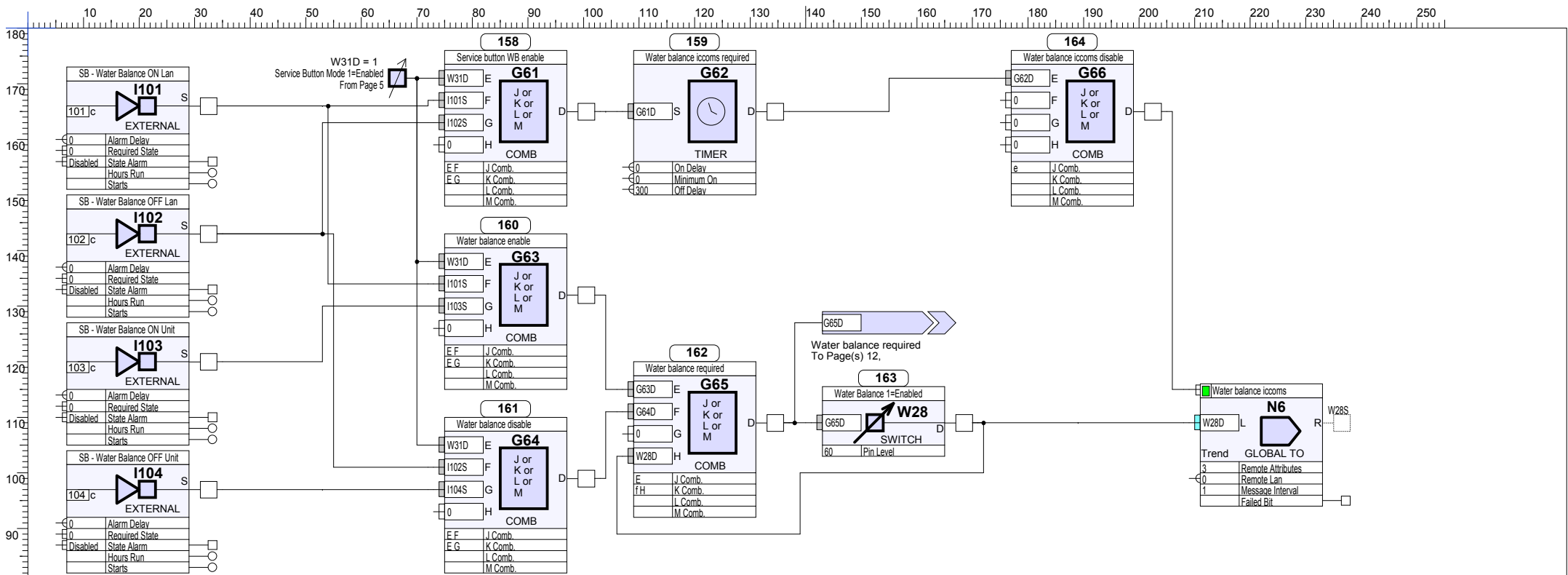

Required Action	Phase 1	Phase 2	Phase 3
Water Balance On for the Lan	No Press	No Press	No Press
Water Balance Off for the Lan	Press	No Press	No Press
Water Balance On for the Unit	No Press	Press	No Press
Water Balance Off for the Unit	Press	Press	No Press

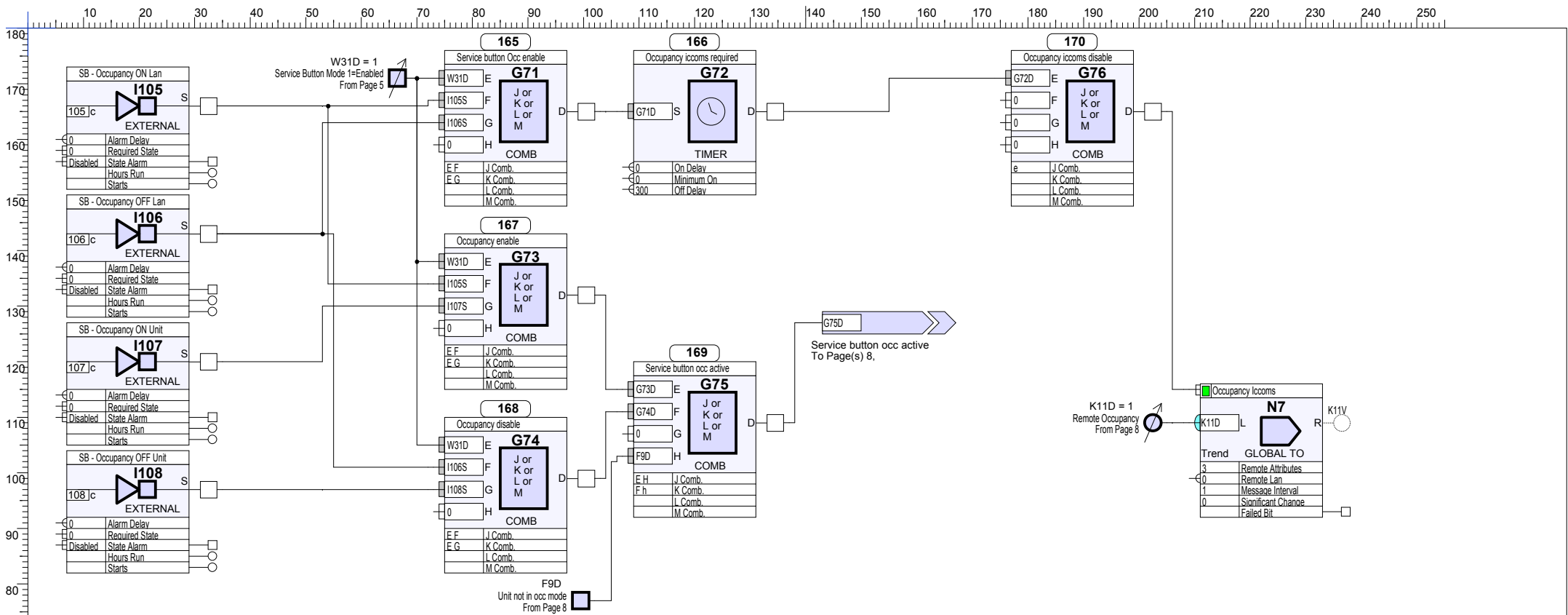

Required Action
 Occupied for the Lan
 Unoccupied for the Lan
 Occupied for the Unit
 Unoccupied for the Unit

Phase 1
 No Press
 Press
 No Press
 Press

Phase 2
 No Press
 No Press
 Press
 Press

Phase 3
 Press
 Press
 Press
 Press

Heat exchanger power estimation.

Heating Power = (Heating medium temperature – Space temperature) * Coil duty * Valve position / 100

Power kW (D) = (Water Supply Temp DegC (E) – Space Temp DegC (F)) * Coil Duty kW/degK (G) * Valve Position %(0-100)(H) * 0.01 (constant)(I)
 Power Btu/s (D) = (Water Supply Temp DegF (E) – Space Temp DegF (F)) * Coil Duty Btu/sDegF (G) * Valve Position %(0-100)(H) * 0.01 (constant)(I)

Cooling Power = (Space temperature – Cooling medium temperature) * Coil duty * Valve position / 100

Power kW (D) = (Space Temp (E) – Water Supply Temp (F)) * Coil Duty kW/degK (G) * Valve Position %(0-100)(H) * 0.01 (constant)(I)
 Power Btu/s (D) = (Space Temp DegF (E) – Water Supply Temp DegF (F)) * Coil Duty Btu/sDegF (G) * Valve Position %(0-100)(H) * 0.01 (constant)(I)
 (1001-25)

1 kW = 0.948608 Btu/s
1 hp = 0.7074163 Btu/s
1 Btu/h/3600 = 1 Btu/s
 (1001-26)

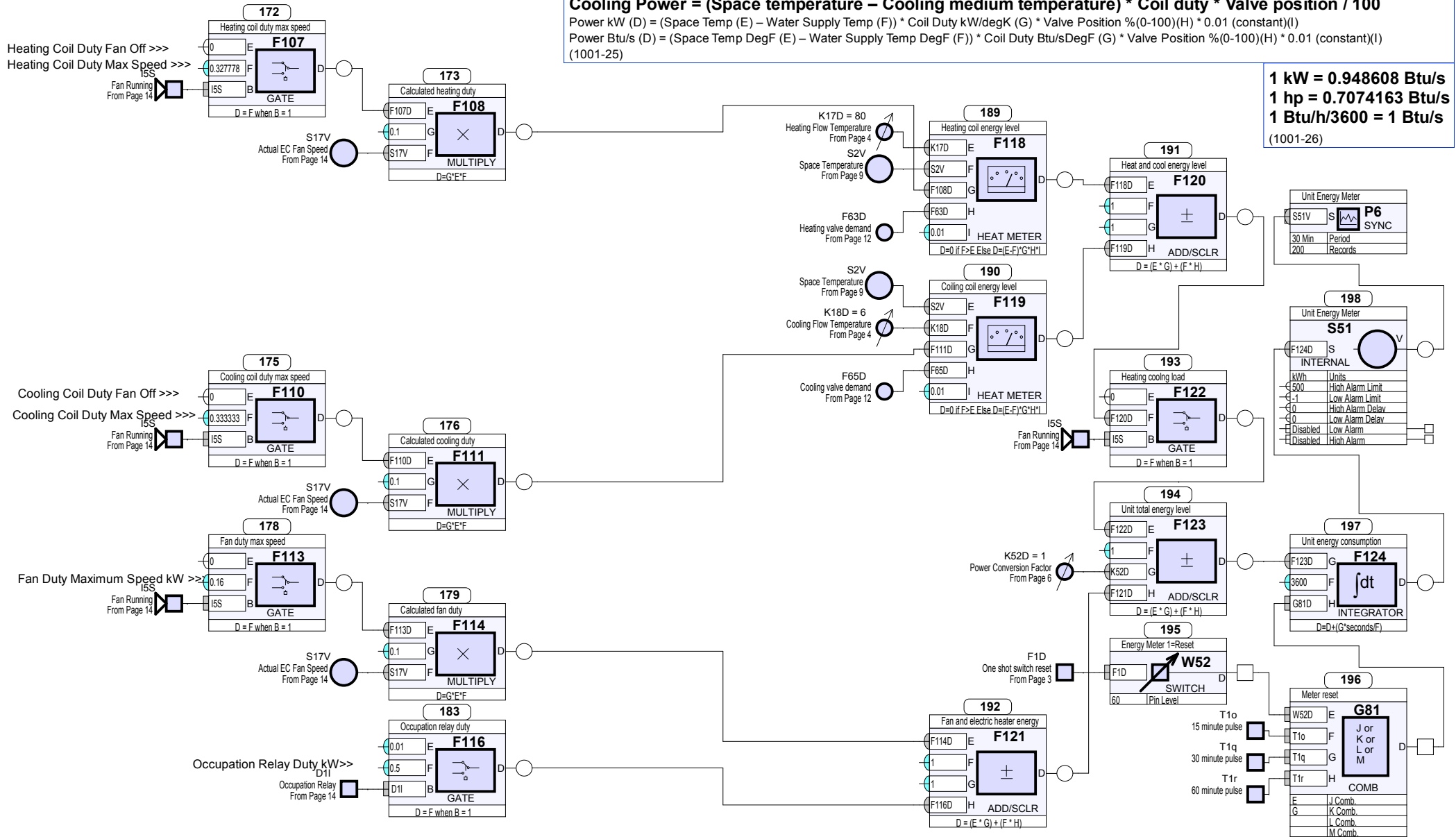

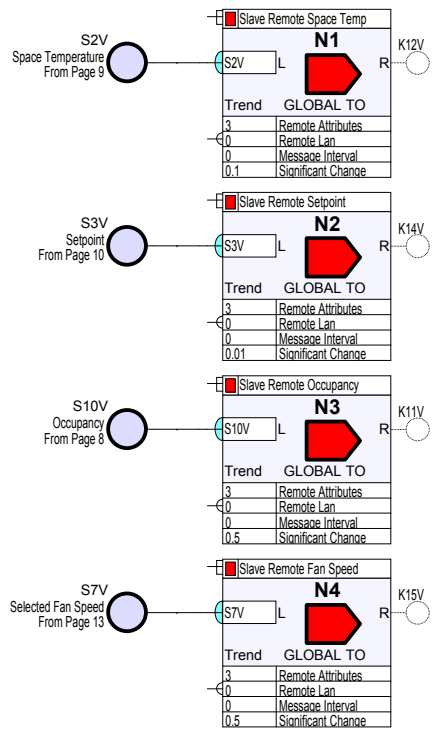

A99 State Holder

A99 State Holder can hold a value to indicate the state of the unit. The meaning of the value is user defined. It is suggested a bit state approach be used where values 1, 2, 4, 8, 16 etc each indicating a separate operation. Summing the values provide a state of the unit. Suggested values:

- 1 = Addressed,
- 2 = Attributes Set,
- 4 = Pre-commissioned,
- 8 = Commissioned,
- 16 = Witnessed,
- 32 = Backed up,
- 64 = (TBC),
- 128 = Has a Problem.

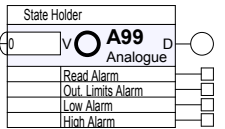

An example of its use. e.g 11 = 1+2+8 = Addressed, Attributes Set and Commissioned.

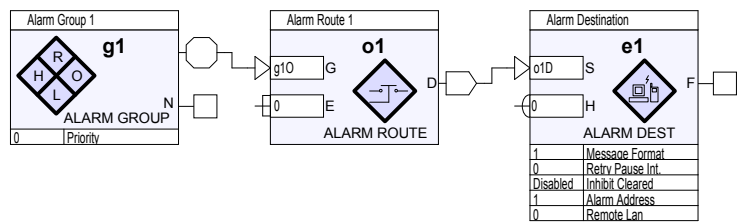
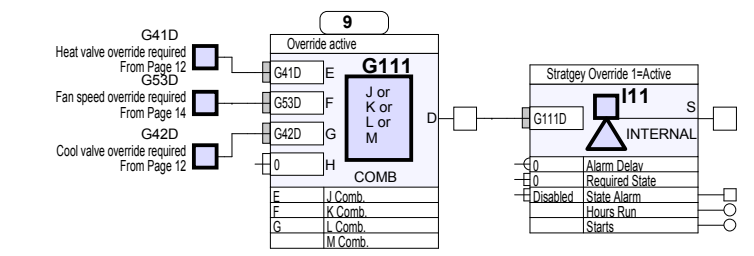

Address Module	
Identifier	
Attribute F	
Attribute G	
Alarm Lan	0
Alarm Address	0
Controller Version	
Strategy Name	FCU EC Fan WR4
Revision	2

BACnet Application Module	
Device Instance	0
Manual Device Instance	0
Send I-Am at Startup	Disabled

MSTP	
Max Info Frames	10

Sensor Number	Type	Label	Units	S.E.T. Part Number	Offset	Source	I/O Channel
1	2	Discharge Air Temperature	DegC			F16D	
2	2	Space Temperature	DegC			F19D	
3	2	Setpoint	DegC			F42D	
7	2	Selected Fan Speed	enum			F77D	
10	2	Occupancy	enum			F7D	
11	2	Heating Demand	%			F52D	
12	2	Cooling Demand	%			F53D	
17	2	Actual EC Fan Speed	V			D9I	
21	1	Local Discharge Air Temp	DegC	101 - 10k Therm DegC T	0		1
22	1	Local Space Temperature	DegC	101 - 10k Therm DegC T	0		2
23	1	Local Setpoint Adjust	DegC	102 - Knob TB 0.5deg trir	0		3
31	2	Room Display Space Temp	DegC			I2O1V	
32	2	Humidity	%RH			I2O2V	
34	2	CO2	ppm			I2O4V	
39	2	Outside Air Temp	DegC			A1D	
40	2	Dewpoint	DegC			I2O3V	
51	2	Unit Energy Meter	kWh			F124D	

Dig In Number	Label	I/O Channel	Source
1	Unit Occupied	0	G18D
2	Unit Unoccupied	0	G20D
3	Unit In Bypass	0	G19D
4	Unit In Standby	0	G21D
5	Fan Running	0	F89D
11	Stratgey Override 1=Active	0	G111D
24	Window Pushbutton PIR	4	
101	SB - Water Balance ON Lan	101	
102	SB - Water Balance OFF Lan	102	
103	SB - Water Balance ON Unit	103	
104	SB - Water Balance OFF Unit	104	
105	SB - Occupancy ON Lan	105	
106	SB - Occupancy OFF Lan	106	
107	SB - Occupancy ON Unit	107	
108	SB - Occupancy OFF Unit	108	

Knob Number	Label	Units	Value	Max. Level	Min. Level	Pin Level
1	Pushbutton PIR Timeout	min	30	1440	0	79
2	Setpoint Adjust Timeout	min	60	1440	0	79
3	Offset Range	DegC	2	10	1	79
4	OCC Deadband	DegC	1	2	0.5	60
5	NOCC Deadband	DegC	25	25	8	60
6	Standby Deadband	DegC	8	8	1	60
7	Heating Setpoint	DegC	19.5	24	8	79
8	Cooling Setpoint	DegC	20.5	34	18	79
11	Remote Occupancy	enum	F11D	3	0	79
12	Remote Space Temperature	DegC	22	30	0	79
13	Remote Setpoint Offset	DegC	0	10	-10	79
14	Remote Setpoint	DegC	22	24	18	79
15	Remote Fan Speed	enum	4	4	0	79
17	Heating Flow Temperature	DegC	80	0	0	79
18	Cooling Flow Temperature	DegC	6	0	0	79
21	Heating Override Value	%	0	100	0	60
22	Cooling Override Value	%	0	100	0	60
28	Fan Speed Override Value EC	%	50	100	0	60
39	Minimum Fan Speed Setpoint	%	37	50	0	79
40	Maximum Fan Speed Setpoint	%	70	100	50	79
44	Room Display Setpoint	DegC	t2O5V	K47D	K48D	79
45	Room Display Fan Speed	enum	t2O7V	255	0	79
47	Setpoint Highlimit	DegC	24	0	0	0
48	Setpoint Lowlimit	DegC	18	0	0	0
51	ECO Mode Deadband Increase	DegC	3	6	2	79
52	Power Conversion Factor		1	0	0	79

Switch Number	Label	Status	Pin Level State
1	Unit Bypass Request 1=Active	G9D	60
11	Remote Shutdown 1=Shutdown	0	79
12	Frost Condition 1=Frost	0	79
21	Heating Override 1=Enabled	0	60
22	Cooling Override 1=Enabled	0	60
27	Fan Override 1=Enabled	0	60
28	Water Balance 1=Enabled	G65D	60
31	Service Button Mode 1=Enabled	1	79
32	Overrides 0=Disabled 1=Enabled	1	79
34	Temperature Select 1=Remote	0	79
35	SP Offset Select 1=Remote	0	79
36	HeatCool Setpoint 1=Separate	0	79
37	Pushbutton TETS KO 1=Fitted	0	79
39	Fan Speed Select 1=Remote	0	79
41	Window Mode 1=Enabled	0	79
42	0=Pushbutton 1=PIR	0	79
45	Fan Off at Setpoint 1=Enabled	0	79
51	Operating Mode 0=Comfort 1=ECO	1	60
52	Energy Meter 1=Reset	F1D	60